

MANUALS

Instruction booklet and **IE**
warning

Installer
User

Maintenance Technician



VICTRIX TERA 24 PLUS

Wall-hung condensing boilers
with sealed chamber (type C)
and fan assisted
or with open chamber (type B)
and fan assisted
which can be coupled
to separate storage tank unit

1.040296ENG



Dear Customer,

Our compliments for having chosen a top-quality Immergas product, able to assure well-being and safety for a long period of time. As an Immergas Customer, you can also count on a qualified after-sales service, prepared and updated to guarantee constant efficiency of your boiler. Read the following pages carefully: you will be able to draw useful suggestions regarding the correct use of the appliance. By respecting these suggestions, you will no doubt be satisfied with your Immergas product.

For any assistance and scheduled maintenance please contact Authorised Immergas After-Sales centres: they have original spare parts and are specifically trained by the manufacturer.

General recommendations

All Immergas products are protected with suitable transport packaging.

The material must be stored in a dry place and protected from weathering.

The instruction book is an integral and essential part of the product and must also be given to the new user in the case of transfer or succession of ownership.

It must be stored with care and consulted carefully, as all of the warnings provide important safety indications for installation, use and maintenance stages.

This instructions manual provides technical information for installing Immergas boilers. As for the other issues related to boiler installation (e.g. safety in the work site, environment protection, injury prevention), it is necessary to comply with the provisions specified in the regulations in force and principles of good practice.

In compliance with the legislation in force, the systems must be designed by qualified professionals, within the dimensional limits established by the Law. Installation and maintenance must be performed in compliance with the regulations in force, according to the manufacturer's instructions and by professionally qualified staff, intended as staff with specific technical skills in the system sector, as envisioned by the Law.

Improper installation or assembly of the appliance and/or Immergas components, accessories, kit and devices can cause unexpected problems to people, animals and objects. Read the instructions provided with the product carefully to ensure proper installation.

Maintenance must be carried out by authorised technical personnel. The Immergas Authorised After-sales Service represents a guarantee of qualifications and professionalism.

The appliance must only be destined for the use for which it has been expressly declared. Any other use will be considered improper and therefore potentially dangerous.

If errors occur during installation, operation and maintenance, due to non-compliance with technical laws in force, standards or instructions contained in this book (or however supplied by the manufacturer), the manufacturer is excluded from any contractual and extra-contractual liability for any damages and the appliance warranty is invalidated.

The company **IMMERGAS S.p.A.**, with registered office in via Cisa Ligure 95 42041 Brescello (RE), declares that the design, manufacturing and after-sales assistance processes comply with the requirements of standard **UNI EN ISO 9001:2008**.

For further details on the product CE marking, request a copy of the Declaration of Conformity from the manufacturer, specifying the appliance model and the language of the country.

The manufacturer declines all liability due to printing or transcription errors, reserving the right to make any modifications to its technical and commercial documents without forewarning.

INDEX

INSTALLER..... page

1	Boiler installation.	5
1.1	Installation recommendations.	5
1.2	Main dimensions.	6
1.3	Antifreeze protection.	6
1.4	Installation inside a recessed frame (Optional).	7
1.5	Boiler connection unit.	8
1.6	Gas connection.	8
1.7	Hydraulic connection.	8
1.8	Electrical connection.	9
1.9	Remote controls and room chrono- thermostats (Optional).	9
1.10	External temperature probe (Optional).	10
1.11	Immergas flue systems.	11
1.12	Tables of resistance factors and equivalent lengths.	11
1.13	Outdoor installation in partially protected area.	13
1.14	Internal installation using a recessed frame with direct air intake.	14
1.15	Concentric horizontal kit installation.	15
1.16	Concentric vertical Kit installation.	16
1.17	Separator kit installation.	17
1.18	Adaptor C9 kit installation.	18
1.19	Ducting of flues or technical slots.	19
1.20	Configuration type B, open chamber and fan assisted for indoors.	19
1.21	Flue exhaust to flue/chimney.	19
1.22	Flues, chimneys and chimney caps.	20
1.23	Water treatment system filling.	20
1.24	System filling.	20
1.25	Filling the condensate drain trap.	20
1.26	Gas system start-up.	20
1.27	Boiler start-up (Ignition).	21
1.28	Circulation pump.	21
1.29	Boiler components.	23
1.30	Kits available on request.	23

USER..... page

2	Use and maintenance instructions.	24
2.1	Cleaning and maintenance.	24
2.2	General warnings.	24
2.3	Control panel.	24
2.4	Using the boiler.	25
2.5	Fault and anomaly signals.	26
2.6	Information Menu.	28
2.7	Boiler shutdown.	28
2.8	Restore central heating system pressure.	28
2.9	Draining the system.	28
2.10	Antifreeze protection.	28
2.11	Case cleaning.	28
2.12	Decommissioning.	28

MAINTENANCE TECHNICIAN..... page

3	Boiler start-up (Initial check).	29
3.1	Boiler Hydraulic diagram.	29
3.2	Wiring diagram.	30
3.3	Troubleshooting.	31
3.4	Converting the boiler to other types of gas.	31
3.5	Calibration of number of fan revs.	31
3.6	Adjustment of the air-gas ratio.	31
3.7	Checks following conversion to another type of gas.	32
3.8	Programming the P.C.B.	33
3.9	Password-protected special functions.	36
3.10	Screed heater function.	36
3.11	Automatic vent function (dI).	36
3.12	Flue installation (Fu).	36
3.13	Maintenance function (MA).	36
3.14	"Chimney sweep function".	37
3.15	Pump anti-block function.	37
3.16	Three-way anti-block system.	37
3.17	Radiators antifreeze function.	37
3.18	Yearly appliance check and maintenance.	37
3.19	Casing removal.	38
3.20	Variable heat output.	40
3.21	Combustion parameters.	41
3.22	Technical data.	42
3.23	Variable heat output.	43
3.24	Combustion parameters.	44
3.25	Technical data.	45
3.26	Key for Data nameplate.	46
3.27	Technical parameters for combination boilers (in compliance with Regulation 813/2013).	47
3.28	Product fiche (in compliance with Regulation 811/2013).	48
3.29	Parameters for filling the package fiche.	49

1 BOILER INSTALLATION.

1.1 INSTALLATION RECOMMENDATIONS.

The Victrix Tera Plus boiler has been designed for wall mounted installation only; for central heating and production of domestic hot water (when the boiler is connected to an external storage tank unit) for domestic use and similar purposes. The place of installation of the appliance and relative Immergas accessories must have suitable features (technical and structural), such as to allow for (always in safe, efficient and comfortable conditions):

- installation (according to the provisions of technical legislation and technical regulations);
- maintenance operations (including scheduled, periodic, routine, special);
- removal (to outdoors in the place for loading and transporting the appliances and components) as well as the eventual replacement of those with appliances and/or equivalent components.

The wall surface must be smooth, without any protrusions or recesses enabling access to the rear part. They are not designed to be installed on plinths or floors (Fig. 1).

By varying the type of installation the classification of the boiler also varies, precisely:

- **Type B₂₃ or B₅₃** boiler if installed using the relevant terminal for air intake directly from the room in which the boiler has been installed.
- **Type C boiler** if installed using concentric pipes or other types of pipes envisioned for the sealed chamber boiler for intake of air and expulsion of flue gas.

Only professionally enabled companies are authorised to install Immergas gas appliances. Installation must be carried out according to regulation standards, current legislation and in compliance with local technical regulations and the required technical procedures.

Important: the manufacturer declines all liability for damages caused by boilers removed from other systems or for any non-conformities of such equipment.

Before installing the appliance, ensure that it is delivered in perfect condition; if in doubt, contact the supplier immediately. Packing materials (staples, nails, plastic bags, polystyrene foam, etc.) constitute a hazard and must be kept out of the reach of children. If the appliance is installed inside or between cabinets, ensure sufficient space for normal servicing; therefore it is advisable to leave clearance of at least 3 cm between the boiler casing and the vertical sides of the cabinet. Leave adequate space above the boiler for possible water and flue removal connections. Keep all flammable objects away from the appliance (paper, rags, plastic, polystyrene, etc.).

Do not place household appliances underneath the boiler as they could be damaged if the safety valve intervenes, if the drain trap is blocked, or if there are leaks from the hydraulic connections; otherwise, the manufacturer cannot be held responsible for any damage caused to the household appliances.

For the aforementioned reasons, we recommend not placing furnishings, furniture, etc. under the boiler.

In the event of malfunctions, faults or incorrect operation, turn the appliance off immediately and contact an authorised company (e.g. the Immergas Technical Assistance centre, which has specifically trained staff and original spare parts). Do not attempt to modify or repair the appliance alone.

Failure to comply with the above implies personal responsibility and invalidates the warranty.

• Installation Standards:

- this boiler can be installed outdoors in a partially protected area. A partially protected area is one in which the boiler is not exposed to the direct action of the weather (rain, snow, hail, etc.).

This type of installation is only possible when permitted by the laws in force in the appliance's country of destination.

- Installation of gas appliances, flue exhaust pipes and combustion air intake pipes is forbidden in places with a fire risk (for example: garages, closed parking stalls), and in potentially dangerous places.
- Installation is prohibited on the vertical projection of the cooking surface.
- Installation is forbidden in places/rooms that constitute public areas of apartment buildings, internal stairways or other escape routes (e.g. floor landings, entrance halls, etc.).
- Installation is also forbidden in places/rooms that constitute public areas of apartment buildings such as cellars, entrance halls, attics, lofts, etc., unless otherwise provided for by local regulations in force.

Attention: installing the wall recessed frame kit must guarantee the boiler stable, efficient support. The recessed frame kit ensures appropriate support only if installed correctly (according to the rules of good practice), following the instructions on its instructions leaflet. The recessed frame for the boiler is not a supporting structure and must not replace the wall removed. It is necessary to position the boiler inside the wall. For safety reasons against any leaks it is necessary to plaster the boiler housing in the brick wall.

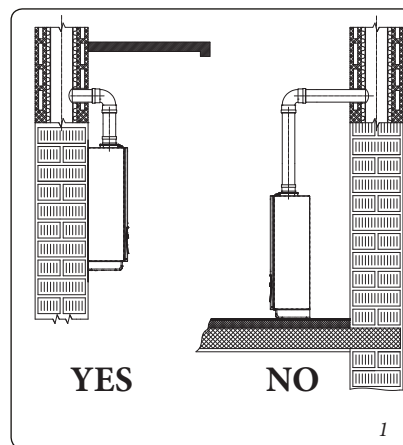

Attention: wall mounting of the boiler must guarantee stable and efficient support for the generator.

The plugs (standard supply) are only to be used to fix the boiler to the wall; they only ensure adequate support if inserted correctly (according to technical standards) in walls made of solid or semi-hollow brick or block. In the case of walls made from hollow brick or block, partitions with limited static properties, or in any case walls other than those indicated, a static test must be carried out to ensure adequate mount.

These boilers are used to heat water to below boiling temperature in atmospheric pressure. They must be connected to a central heating system and domestic hot water circuit suited to their performance and capacity.

Attention: the storage tank unit must also be installed in an environment in which the temperature cannot fall below 0°C.

"Anti-legionella" heat treatment of the storage tank (activated by the specific function present on the predisposed thermoregulation systems): during this stage, the temperature of the water inside the storage tank exceeds 60°C with a relative risk of burns. Keep this domestic hot water treatment under control (and inform the users) to prevent unforeseeable damage to people, animals, things. If required install a thermostatic valve on the domestic hot water outlet to prevent scalding.

INSTALLER

USER

MAINTENANCE TECHNICIAN

1.2 MAIN DIMENSIONS.

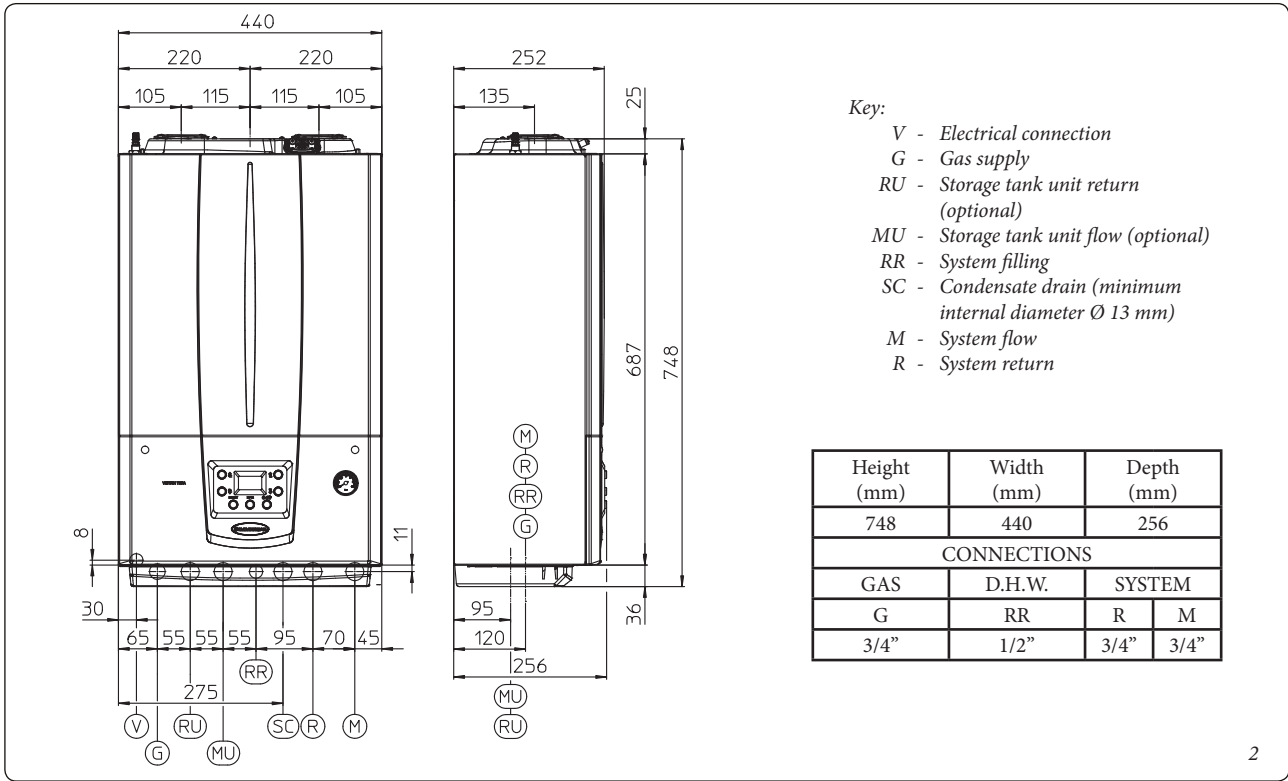

1.3 ANTIFREEZE PROTECTION.

Minimum temperature -5°C. The boiler comes standard with an antifreeze function that activates the pump and burner when the system water temperature in the boiler falls below 4°C. *In these conditions the boiler is protected against freezing to an ambient temperature of -5°C.*

Minimum temperature -15°C. If the boiler is installed in a place where the temperature drops below -5°C, the appliance can freeze. *To prevent the risk of freezing follow the instructions below:*

- protect the central heating circuit from freezing by inserting a good-quality antifreeze liquid into this circuit, which is specially suited for central heating systems and which is manufacturer guaranteed not to cause damage to the heat exchanger or other components of the boiler. The antifreeze liquid must not be harmful to one's health. The instructions of the manufacturer of this liquid must be followed scrupulously regarding the percentage necessary with respect to the minimum temperature at which the system must be kept.

Attention: the excessive use of glycol could jeopardise the proper functioning of the appliance.

An aqueous solution must be made with potential pollution class of water 2 (EN 1717:2002 or local standards in force).

The materials used for the central heating circuit of Immergas boilers withstand ethylene and propylene glycol based antifreeze liquids (if the mixtures are prepared perfectly).

For life and possible disposal, follow the supplier's instructions.

- Protect the domestic hot water circuit against freezing by using an accessory that is supplied on request (antifreeze kit) comprising two electric heating elements, the relevant wiring and a control thermostat (carefully read the installation instructions contained in the accessory kit pack).

In these conditions the boiler is protected against freezing to temperature of -15°C.

Boiler antifreeze protection (both -5°C and -15°C) is thus ensured only if:

- the boiler is correctly connected to gas and electricity power supply circuits;
- the boiler is powered constantly;
- the boiler is not in "off" mode.
- the boiler is not in anomaly conditions (Parag. 2.5);
- the essential components of the boiler and/or antifreeze kit are not faulty.

The warranty does not cover damage due to interruption of the electrical power supply and failure to comply with that stated on the previous page.

N.B.: if the boiler is installed in places where the temperature falls below 0°C the domestic hot water and central heating attachment pipes must be insulated.

The water in the storage tank unit is not protected against freezing when the boiler is switched off.

1.4 INSTALLATION INSIDE A RECESSED FRAME (OPTIONAL).

The boiler is designed for installation inside the Immergas recessed frame (supplied as optional). The necessary parts for this type of installation (brackets) must also be purchased separately as optional kit.

To install proceed as follows:

- Install the bracket (2) inside the recessed frame fixing it with the screws (3) in the pre-drilled holes (Fig. 3).
- Hang the boiler (4) to the bracket (2) (Fig. 4).
- Block the boiler (4) by mounting the brackets (5) and fixing them with their screws (6) (Fig. 5).

The brackets (5) used to centre the boiler on the frame and hold it in place stop against the frame (1) so do not require fixing to the frame itself.

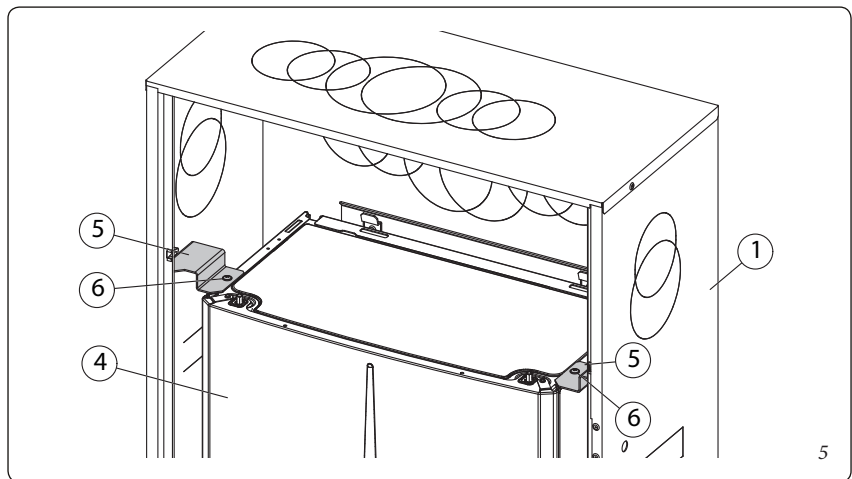
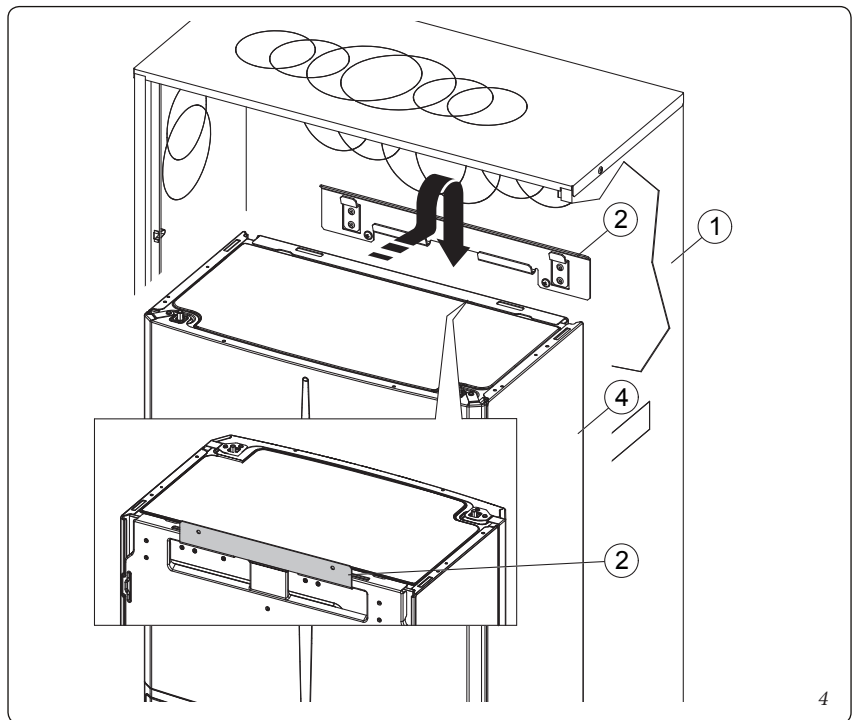
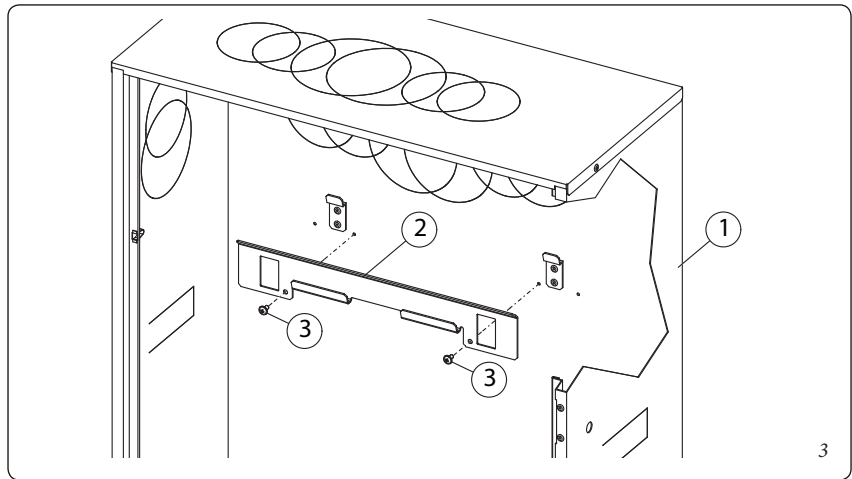

INSTALLER

USER

MAINTENANCE TECHNICIAN

1.5 BOILER CONNECTION UNIT.

The connection unit consisting of all the necessary parts to perform the hydraulic and gas system connections of the appliance comes as optional kit, perform the connections respecting the arrangement of Fig. 6 based on the type of installation to be made.

1.6 GAS CONNECTION.

Our boilers are designed to operate with methane gas (G20) and LPG. Supply pipes must be the same as or larger than the 3/4" G boiler fitting. Before connecting the gas line, carefully clean inside all the fuel feed system pipes to remove any residue that could impair boiler efficiency. Also make sure the gas corresponds to that for which the boiler is prepared (see boiler data nameplate). If different, the boiler must be converted for operation with the other type of gas (see converting appliance for other gas types). It is also important to check the dynamic pressure of the mains (methane or LPG) used to supply the boiler, which must comply with EN 437 and its attachment, as insufficient levels may reduce generator output and cause discomfort to the user. Ensure correct gas cock connection. The gas supply pipe must be suitably dimensioned according to current regulations in order to guarantee correct gas flow rate to the burner even in conditions of maximum generator output and to guarantee appliance efficiency (technical specifications). The coupling system must conform to standards in force.

Fuel gas quality. The appliance was designed to operate with combustible gas free of impurities; otherwise it is advisable to fit special filters upstream of the appliance to restore the purity of the fuel.

Storage tanks (in case of supply from LPG depot).

- New LPG storage tanks may contain residual inert gases (nitrogen) that degrade the mixture delivered to the appliance causing functioning anomalies.
- Due to the composition of the LPG mixture, layering of the mixture components may occur during the period of storage in the tanks. This can cause a variation in the heating power of the mixture delivered to the appliance, with subsequent change in its performance.

1.7 HYDRAULIC CONNECTION.

Attention: in order not to void the condensation module warranty, before making the boiler connections, carefully wash the heating system (pipes, radiators, etc.) with special pickling or descaling products to remove any deposits that could compromise correct boiler operation.

A treatment of the heating and water system water is required, in compliance with the technical standards in force, in order to protect the system and the appliance from deposits (e.g. scale), slurry or other hazardous deposits. In order not to void the heat exchanger warranty, you are required to comply with what has been prescribed in Paragraph 1.23.

Water connections must be made in a rational way using the couplings on the boiler template.

Attention: the manufacturer declines all liability in the event of damage caused by the installation of an automatic filling system.

In order to meet the system requirements established by EN 1717 in terms of pollution of drinking water, we recommend installing the IMMERGAS anti-backflow kit to be used upstream of the cold water inlet connection of the boiler. We also recommend using a category 1, 2 or 3 heat transfer fluid (ex: water + glycol) in the boiler's primary circuit (C.H. circuit), as defined in standard EN 1717.

Attention: to preserve the duration and the efficiency features of the appliance, in the presence of water whose features can lead to the deposit of scale, installation of the "polyphosphate dispenser" kit is recommended.

3 bar safety valve. Discharge of the safety valve has been conveyed to the condensate drain trap outlet. Consequently, in the event of valve intervention, the discharged liquid will end up in the sewer system through the drain pipe of the condensate drain trap.

In any case the lower part of the appliance is fitted with a drain fitting (Ref. 3 Fig. 6) with the relative closure cap to check for the presence of liquid in the discharge circuit and to check the intervention of the 3 bar safety valve.

Condensate drain. To drain the condensate produced by the appliance, it is necessary to connect to the drainage system by means of acid condensate resistant pipes, with an internal Ø of at least 13 mm. The system connecting the appliance to the drainage system must be carried out in such a way as to prevent occlusion and freezing of the liquid contained in it. Before appliance ignition, ensure that the condensate can be correctly removed. After first ignition, check that the drain trap is filled with condensate (Para. 1.25). Also, comply with national and local regulations on discharging waste waters.

In the event condensate is not discharged into the wastewater drainage system, a condensate neutraliser must be installed to ensure compliance with the parameters established by the legislation in force.

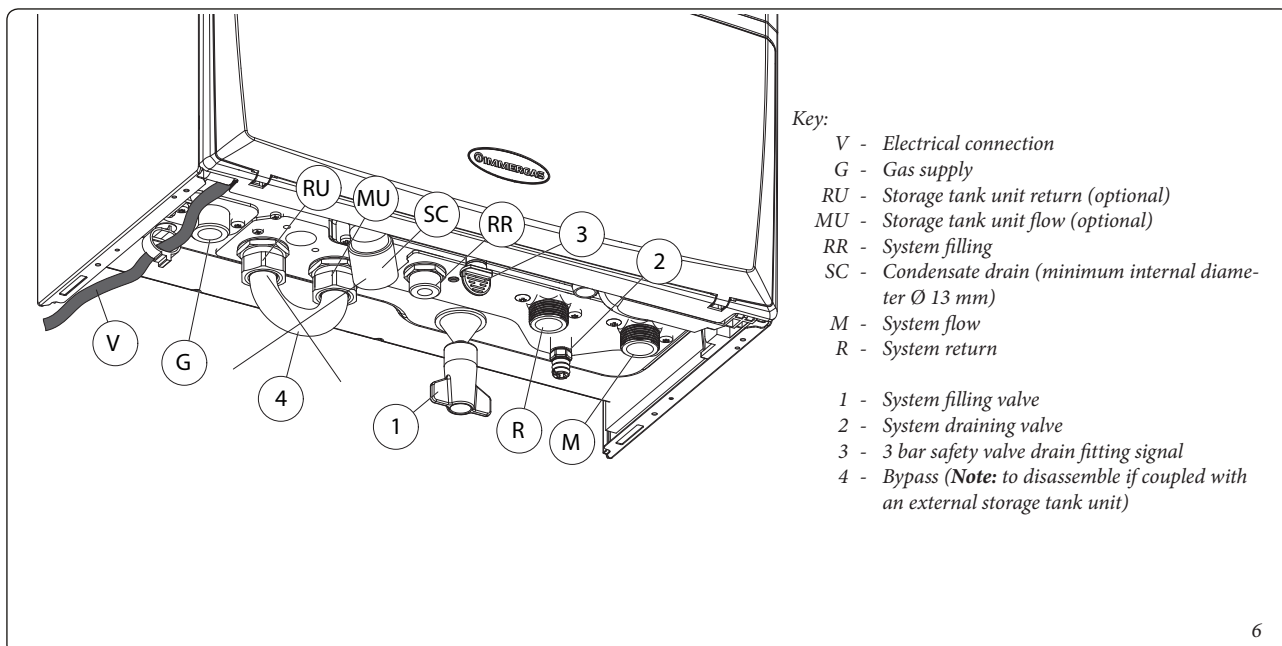

1.8 ELECTRICAL CONNECTION:

The appliance has an IPX5D protection degree; electrical safety of the appliance is achieved only when it is connected properly to an efficient earthing system, as specified by current safety standards.

Attention: the manufacturer declines any responsibility for damage or physical injury caused by failure to connect the boiler to an efficient earth system or failure to comply with the reference standards.

- **Open the control panel connections compartment (Fig. 7).**

To carry out electrical connections, all you have to do is open the connections compartment as follows (Fig. 7):

- Disassemble the cover (Fig. 52).
- Disassemble the cover (b)
 - 1) Loosen the screw (a).
 - 2) Press the two hooks on the connections compartment cover.
 - 3) Remove the cover (b) from the control panel (c).
- At this point, it is possible to access the terminal board (d).

Also ensure that the electrical installation corresponds to maximum absorbed power specifications as shown on the boiler data nameplate. Boilers are supplied complete with an "X" type power cable without plug. The power supply cable must be connected to a 230V ±10% / 50Hz mains supply respecting L-N polarity and earth connection; this network must also have a multi-pole circuit breaker with class III overvoltage category. To protect from possible dispersions of DC voltage, it is necessary to provide a type A differential safety device.

When replacing the power supply cable, contact a qualified company (e.g. the Authorised After-Sales Technical Assistance Service). The power cable must be laid as shown (Fig. 6). In the event of mains fuse replacement on the P.C.B., use a 3.15A quick-blow fuse. For the main power supply to the appliance, never use adapters, multiple sockets or extension leads.

N.B.: connect terminals 36 and 37 to electrically connect the boiler to the storage tank unit, eliminating resistance R8 in the boiler (Fig. 37).

Installation with system operating at direct low temperature. The boiler can directly supply a low-temperature system by setting the flow temperature adjustment range "t0" and "t1" (Par. 3.8). In this situation it is good practice to insert a relevant safety kit (optional) made up from a thermostat (with adjustable temperature). The thermostat must be positioned on the system flow pipe at a distance of at least 2 metres from the boiler.

1.9 REMOTE CONTROLS AND ROOM CHRONO-THERMOSTATS (OPTIONAL).

The boiler is prepared for the application of room chrono-thermostats or remote controls, which are available as optional kits (Fig. 8). All Immergas chrono-thermostats are connected with 2 wires only. Carefully read the user and assembly instructions contained in the accessory kit.

- On/Off Immergas digital chrono-thermostat. The chrono-thermostat allows:
 - set two room temperature value: one for day (comfort temperature) and one for night (reduced temperature);
 - set a weekly programme with four daily switch on and switch off times;
 - selecting the required function mode from the various possible alternatives:
 - manual operation (with adjustable temperature).
 - automatic operation (with set programme).
 - forced automatic operation (momentarily changing the temperature of the automatic programme).

The chrono-thermostat is powered by two 1.5V LR 6 type alkaline batteries.

- Comando Amico Remoto Remote Control Device^{V2} (CAR^{V2}) with climate chrono-thermostat function. In addition to the functions described in the previous point, the CAR^{V2} panel enables the user to control all the important information regarding operation of the appliance and the heating system with the opportunity to easily intervene on the previously set parameters, without having to go to where the appliance is installed. The panel is provided with

self-diagnosis to display any boiler functioning anomalies. The climate chrono-thermostat incorporated into the remote panel enables the system flow temperature to be adjusted to the actual needs of the room being heated, in order to obtain the desired room temperature with extreme precision and therefore with evident saving in running costs. The CAR^{V2} is fed directly by the boiler by means of the same 2 wires used for the transmission of data between the boiler and device.

Comando Amico Remoto Remote Control^{V2} or On/Off chrono-thermostat electrical connections (Optional). The operations described below must be performed after having removed the voltage from the appliance. Any thermostat or On/Off environment chrono-thermostat must be connected to clamps 44/40 and 41 eliminating jumper X40 (Fig. 37). Make sure that the On/Off thermostat contact is of the "clean" type, i.e. independent of the mains voltage, otherwise the P.C.B. would be damaged. Any Comando Amico Remoto Remote Control^{V2} must be connected to clamps 44/40 and 41 eliminating jumper X40 on the P.C.B., paying attention not to invert the polarity in the connections (Fig. 37). The boiler can only be connected to one remote control.

Important: if the Comando Amico Remoto Remote Control^{V2} or any other On/Off chrono-thermostat is used, arrange two separate lines in compliance with current regulations regarding electrical systems. No boiler pipes must ever be used to earth the electric system or telephone lines. Ensure elimination of this risk before making the boiler electrical connections.

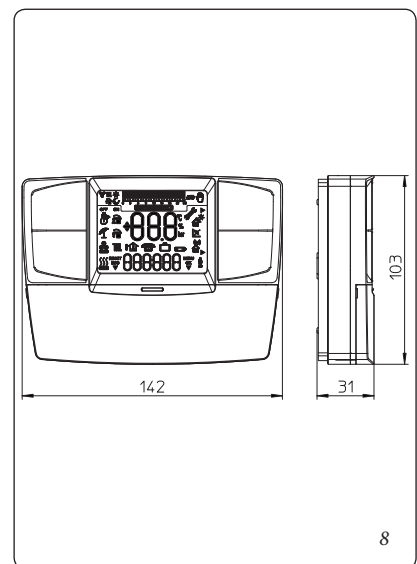
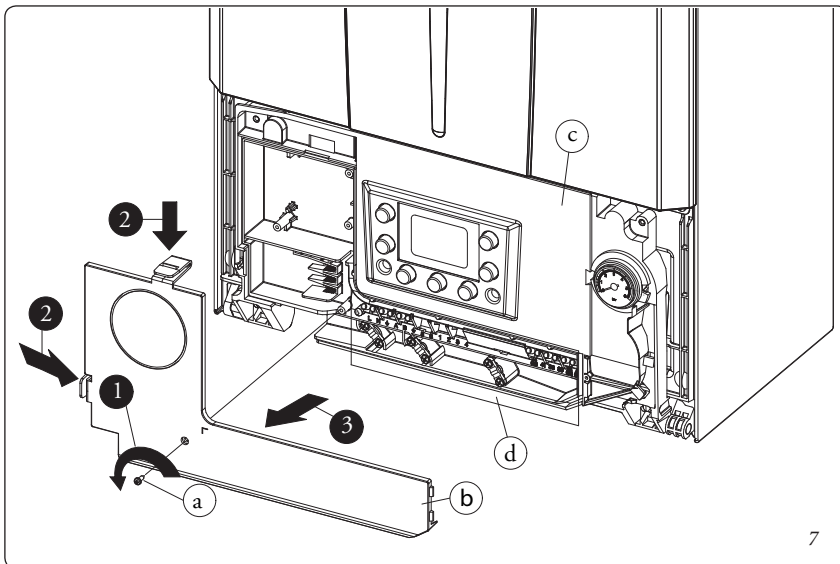

1.10 EXTERNAL TEMPERATURE PROBE (OPTIONAL).

The boiler is designed for the application of the external temperature probe (Fig. 9), which is available as an optional kit. Refer to the relative instruction sheet for positioning of the external probe.

The probe can be connected directly to the boiler electrical system and allows the max. system flow temperature to be automatically decreased when the external temperature increases, in order to adjust the heat supplied to the system according to the change in external temperature. The external probe always operates when connected, regardless of the presence or type of room chrono-thermostat used and can work in combination with Immergas chrono-thermostats. The correlation between system flow temperature and external temperature is determined by the position of the central heating selector switch on the boiler control panel (or on the CAR^{V2} control panel if connected to the boiler) according to the curves shown in the diagram (Fig. 10). The electric connection of the external probe must be made on clamps 38 and 39 on the terminal board in the boiler control panel (Fig. 37).

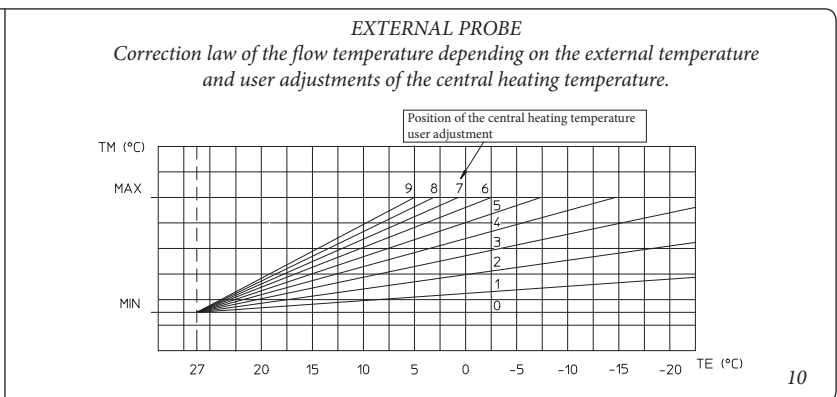
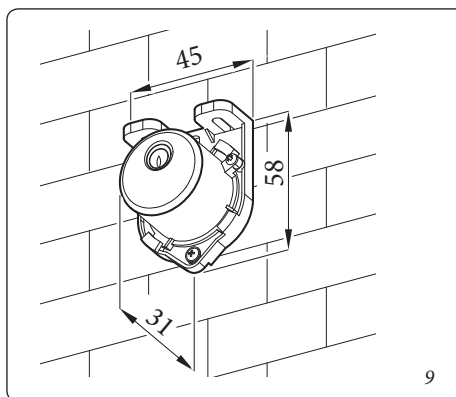

1.11 IMMERGAS FLUE SYSTEMS.

Immergas supplies various solutions separately from the boilers regarding the installation of air intake terminals and flue exhaust, which are fundamental for boiler operation.

Attention: the boiler must be installed exclusively with an original Immergas “Green Range” inspectionable air intake system and flue gas extraction system made of plastic, with the exception of the C6 configuration, as required by the regulations in force.

The plastic pipes cannot be installed outdoors, for tracts longer than 40 cm, without suitable protection from UV rays and other atmospheric agents.

This flue can be identified by an identification mark and special distinctive marking bearing the note "only for condensation boilers".

- Resistance factors and equivalent lengths. Each flue component has a *Resistance Factor* based on experimental tests and specified in the table below. The Resistance Factor for individual components is independent from the type of boiler on which it is installed and has a dimensionless size. It is however, conditioned by the temperature of the fluids that pass through the pipe and therefore, varies according to applications for air intake or flue exhaust. Each single component has a resistance corresponding to a certain length in metres of pipe of the same diameter; the so-called *equivalent length*, can be obtained from the ratio between the relative Resistance Factors. *All boilers have an experimentally obtainable maximum Resistance Factor equal to 100.* The maximum Resistance Factor allowed corresponds to the resistance encountered with the maximum allowed pipe length for each type of Terminal Kit. This information allows calculations to be made to verify the possibility of setting up various flue configurations.

- Positioning of the gaskets (black) for “green range” flue extraction systems.** Position the gasket correctly (for bends and extensions) (Fig. 11):

- gasket (A) with notches, to use for bends;
- gasket (B) without notches, to use for extensions;

N.B.: if necessary, to ease the push-fitting, spread the elements with commonly-used talc.

- Coupling extension pipes and concentric elbows. To install push-fitting extensions with other elements of the flue, proceed as follows: Install the concentric pipe or elbow with the male side (smooth) on the female side (with lip seal) to the end stop on the previously installed element in order to ensure sealing efficiency of the coupling.





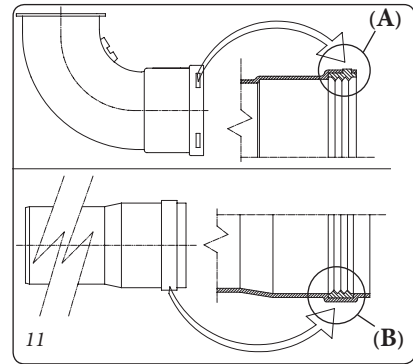





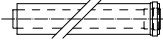

Attention: if the exhaust terminal and/or concentric extension pipe needs shortening, consider that the internal duct must always protrude by 5 mm with respect to the external duct.

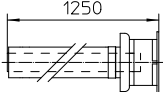
- N.B.:** for safety purposes, do not obstruct the boiler intake/exhaust terminal, even temporarily.
- N.B.:** when installing horizontal pipes, a minimum inclination of 3% must be maintained and a section clip with pin must be installed every 3 metres.
- Installation inside the recessed frame. In this mode, install the flue according to your needs using the appropriate pre-sections in the frame to exit from its clearances.

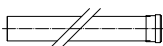
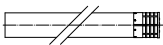

1.12 TABLES OF RESISTANCE FACTORS AND EQUIVALENT LENGTHS.

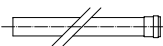
TYPE OF DUCT	Resistance Factor (R)	Equivalent length in m of concentric pipe Ø 80/125
Concentric pipe 80/125 Ø m 1	2.1	1
Concentric bend 90° 80/125 Ø	3.0	1.4
Concentric bend 45° 80/125 Ø	2.1	1
Terminal complete with concentric horizontal intake-exhaust Ø 80/125	2.8	1.3
Terminal complete with concentric vertical intake-exhaust 80/125 Ø	3.6	1.7
Concentric bend 90° Ø 80/125 with inspection	3.4	1.6
Stub pipe with inspection Ø 80/125	3.4	1.6

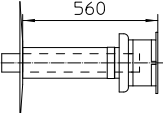
TYPE OF DUCT		Resistance Factor (R)	Equivalent length in m of concentric pipe Ø 60/100	Equivalent length in metres of pipe Ø 80	Equivalent length in metres of pipe 60 Ø	Equivalent length in m of concentric pipe Ø 80/125
Concentric pipe Ø 60/100 m 1		Intake and Exhaust 6.4	m 1	Intake m 7.3	Exhaust m 1.9	m 3.0
				Exhaust m 5.3		
Concentric bend 90° Ø 60/100		Intake and Exhaust 8.2	1.3 m	Intake m 9.4	Exhaust m 2.5	m 3.9
				Exhaust m 6.8		
Concentric bend 45° Ø 60/100		Intake and Exhaust 6.4	m 1	Intake m 7.3	Exhaust m 1.9	m 3.0
				Exhaust m 5.3		
Terminal complete with concentric horizontal intake-exhaust Ø 60/100		Intake and Exhaust 15	m 2.3	Intake m 17.2	Exhaust m 4.5	m 7.1
				Exhaust m 12.5		
Concentric horizontal intake- exhaust terminal Ø 60/100		Intake and Exhaust 10	m 1.5	Intake m 11.5	Exhaust m 3.0	4.7 m
				Exhaust m 8.3		
Terminal complete with concentric vertical intake-exhaust Ø 60/100		Intake and Exhaust 16.3	m 2.5	Intake m 18.7	Exhaust m 4.9	m 7.7
				Exhaust m 13.6		
Concentric vertical intake-exhaust terminal Ø 60/100		Intake and Exhaust 9	1.4 m	Intake m 10.3	Exhaust m 2.7	m 4.3
				Exhaust m 7.5		
Pipe Ø 80 m 1		Intake 0.87 Exhaust 1.2	m 0.1	Intake m 1.0	Exhaust m 0.4	m 0.4
			m 0.2	Exhaust m 1.0		m 0.5
Complete intake terminal Ø 80 m 1		Intake 3	m 0.5	Intake m 3.4	Exhaust m 0.9	1.4 m
Intake terminal Ø 80 Exhaust terminal Ø 80		Intake 2.2 Exhaust 1.9	m 0.35	Intake m 2.5	Exhaust m 0.6	m 1
			m 0.3	Exhaust m 1.6		m 0.9
Bend 90° 80 Ø		Intake 1.9 Exhaust 2.6	m 0.3	Intake m 2.2	Exhaust m 0.8	m 0.9
			m 0.4	Exhaust m 2.1		m 1.2
45° 80 Ø Bend		Intake 1.2 Exhaust 1.6	m 0.2	Intake m 1.4	Exhaust m 0.5	m 0.5
			m 0.25	Exhaust m 1.3		0.7
Pipe Ø 60 m 1 for ducting		Exhaust 3.3	m 0.5	Intake 3.8	Exhaust m 1.0	m 1.5
				Exhaust 2.7		
Bend 90° Ø 60 for ducting		Exhaust 3.5	m 0.55	Intake 4.0	Exhaust m 1.1	1.6 m
				Exhaust 2.9		
Reduction Ø 80/60		Intake and Exhaust 2.6	m 0.4	Intake m 3.0	Exhaust m 0.8	m 1.2
				Exhaust m 2.1		
Terminal complete with exhaust vertical Ø 60 for ducting		Exhaust 12.2	1.9 m	Intake m 14	Exhaust m 3.7	m 5.8
				Exhaust m 10.1		

1.13 OUTDOOR INSTALLATION IN PARTIALLY PROTECTED AREA.

N.B.: a partially protected location is one in which the appliance is not exposed to the direct action of the weather (rain, snow, hail, etc.).

• **Configuration type B, open chamber and fan assisted.**

Using the special coverage kit one can achieve direct air intake (Fig. 12) and flue gas exhaust in a single chimney or directly outside. In this configuration it is possible to install the boiler in a partially protected place. In this configuration the boiler is classified as type B.

With this configuration:

- air intake takes place directly from the environment in which the appliance is installed (external);
- the flue gas exhaust must be connected to its own single flue (B₃₃) or ducted directly outside via a vertical terminal for direct exhaust (B₃₃) or via an Immergas ducting system (B₃₃).

The technical regulations in force must be respected.

- **Coverage kit assembly (Fig. 13).** Remove the two plugs from the lateral intake holes. Now cover the left intake hole using the relevant plate, fixing it onto the right side using the 2 previously-removed screws. Install the Ø 80 outlet flange on the central hole of the boiler, taking care to insert the gasket supplied with the kit and tighten by means of the screws provided. Install the upper cover, fixing it using the 4 screws present in the kit, positioning the relevant gaskets. Engage the 90° Ø 80 bend with the male end (smooth) in the female end (with lip seal) of the Ø 80 flange unit until it stops. Introduce the gasket, making it run along the bend. Fix it using the metal sheet plate and tighten by means of the clips present in the kit, making sure to block the 4 gasket flaps. Fit the male end (smooth) of the exhaust terminal into the female end of the bend 90° Ø 80, making sure that the relevant wall sealing plate is already fitted; this will ensure hold and joining of the elements making up the kit.

Max. length of exhaust duct. The flue pipe (both vertical or horizontal) can be extended to a max. length of 30 linear metres.

- **Coupling of extension pipes.** To install push-fitting extensions with other elements of the flue, proceed as follows: Install the pipe or elbow with the male side (smooth) in the female section (with lip seal) to the stop on the previously installed element. This will ensure sealing efficiency of the coupling.
- **Configuration without cover kit in a partially protected location (type C boiler)**

N.B.: a partially protected location is one in which the appliance is not exposed to the direct action of the weather (rain, snow, hail, etc.).

By leaving the side plugs fitted it is possible to install the appliance externally without the cover kit. Installation takes place using the Ø60/100 and Ø 80/125 concentric intake/exhaust kits. Refer to the paragraph on indoor installation. In this configuration the upper cover kit guarantees additional protection for the boiler. It is recommended but not compulsory. The Ø 80/80 separating device cannot be used in this configuration.

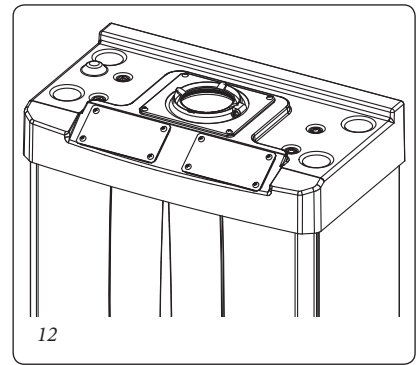

12

INSTALLER

USER

MAINTENANCE TECHNICIAN

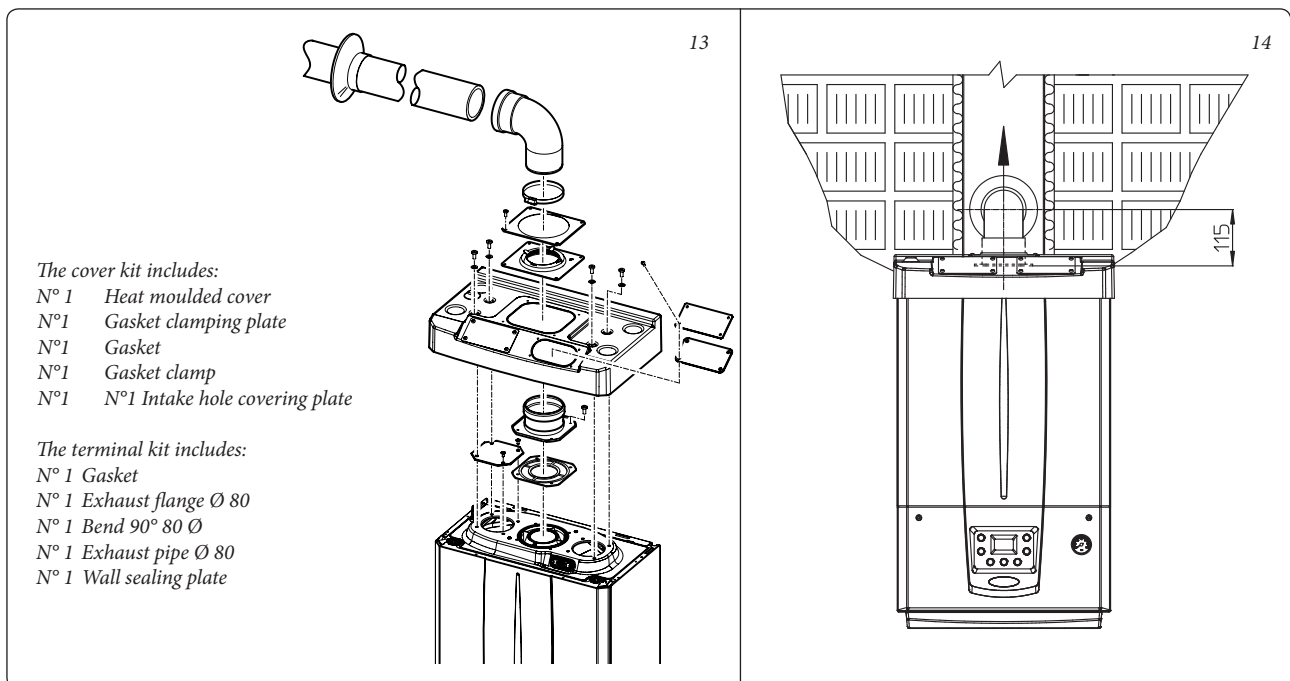

The cover kit includes:

- N° 1 Heat moulded cover
- N°1 Gasket clamping plate
- N°1 Gasket
- N°1 Gasket clamp
- N°1 N°1 Intake hole covering plate

The terminal kit includes:

- N° 1 Gasket
- N° 1 Exhaust flange Ø 80
- N° 1 Bend 90° 80 Ø
- N° 1 Exhaust pipe Ø 80
- N° 1 Wall sealing plate

1.14 INTERNAL INSTALLATION USING A RECESSED FRAME WITH DIRECT AIR INTAKE

- Configuration type B, open chamber and fan assisted.

Using a kit separator one can achieve direct air intake (Fig. 16) and flue gas exhaust in a single chimney or directly outside. In this configuration the boiler is classified as type B₂₃.

With this configuration:

- air intake takes place directly from the environment in which the appliance is installed (the recessed frame is ventilated), and only functions in permanently ventilated rooms;
- the flue gas exhaust must be connected to its own individual flue or channelled directly into the external atmosphere.

The technical regulations in force must be respected.

Separator kit installation: install the discharge flange on the central hole of the boiler, positioning the relative gasket with the circular projections downwards in contact with the boiler flange, and tighten using the hex screws with flat tip contained in the kit. Remove the flat flange present in the lateral hole with respect to the central one (according to needs) and replace it with the intake flange, positioning its gasket already present in the boiler and tighten using the supplied self-threading screws. Fit the male side (smooth) to the bends in the female side of the flanges.

The intake bend must face the rear side of the boiler.

Fit the exhaust pipe with the male side (smooth) to the female side of the bend up to the end stop, making sure that the internal wall sealing plate has been fitted and connecting the required flue according to personal requirements.

Max. length of exhaust duct. The flue pipe (both vertical or horizontal) can be extended to a max. length of 30 linear metres.

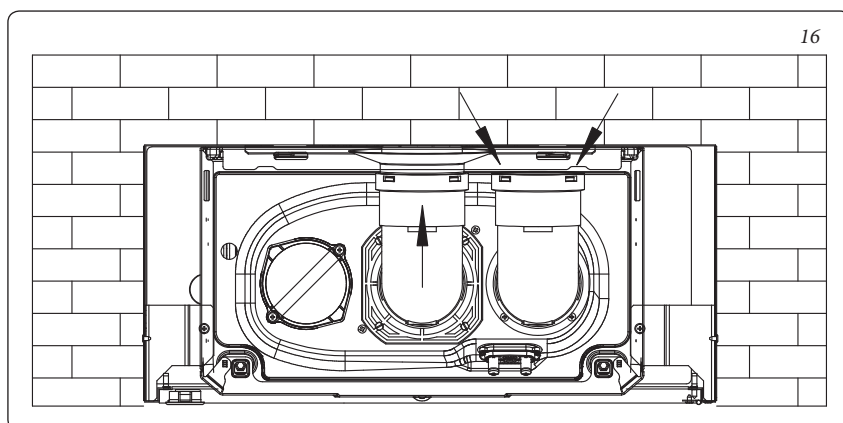
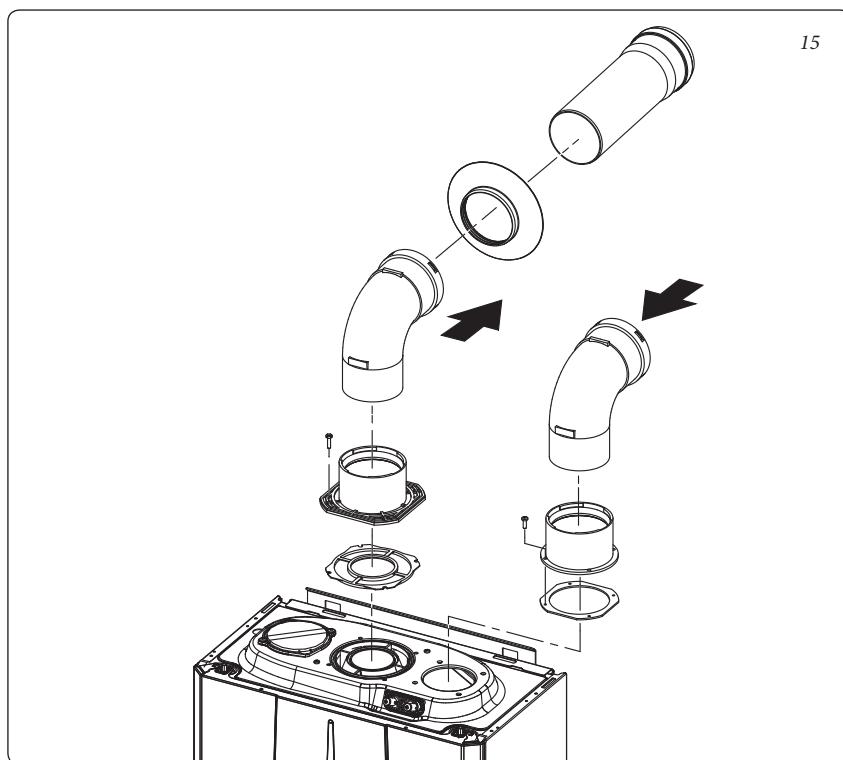

1.15 CONCENTRIC HORIZONTAL KIT INSTALLATION.

Type C configuration, sealed chamber and fan assisted.

The position of the terminal (in terms of distances from openings, overlooking buildings, floor, etc.) must be in compliance with the regulations in force.

This terminal is connected directly to the outside of the building for air intake and flue gas exhaust. The horizontal kit can be installed with the rear, right side, left side or front outlet. For installation with frontal outlet, one must use the fixing plate and a concentric bend coupling in order to ensure sufficient space to carry out the tests required by law upon commissioning.

- External grid. Both the Ø 60/100 and Ø 80/125 intake/exhaust terminal, if properly installed, is pleasant to look at on the outside of the building. Make sure that the external silicone wall sealing plate is properly inserted in the wall.

N.B.: for proper system operation the terminal with grid must be installed correctly ensuring that, the "high" indication on the terminal is observed during installation.

Horizontal intake-exhaust kit Ø 60/100. Kit assembly (Fig. 17): install the bend with flange (2) on the central hole of the boiler, positioning gasket (1) with the circular projections downwards in contact with the boiler flange, and tighten using the screws present in the kit. Fit the Ø 60/100 (3) concentric terminal pipe with the male side (smooth) to the female side of the bend (2) up to the end stop; making sure that the internal and external wall sealing plate have been fitted, this will ensure sealing and joining of the elements making up the kit.

- Extensions for Ø 60/100 horizontal kit (Fig. 18). The kit with this configuration can be extended up to a *max. 12.9 horizontal m* including the terminal with grid and excluding the concentric bend leaving the boiler. This configuration corresponds to a resistance factor of 100. In this case the special extensions must be requested.

Immergas also provides a Ø 60/100 simplified terminal, which in combination with its extension kits allows you to reach a maximum extension of 11.9 metres.

Horizontal intake-exhaust kit Ø 80/125. Kit assembly (Fig. 19): to install the kit Ø 80/125 one must use the flanged adaptor kit in order to install the flue system Ø 80/125. Install the flanged adaptor (2) on the central hole of the boiler, positioning gasket (1) with the circular projections downwards in contact with the boiler flange, and tighten using the screws contained in the kit. Engage the bend (3) with the male side (smooth) to the end stop on the adaptor (1). Fit

the Ø 80/125 (5) concentric terminal pipe with the male side (smooth) to the female side of the bend (4) (with lip seals) up to the end top; making sure that the internal (6) and external wall sealing plate (7) have been fitted, this will ensure sealing and joining of the elements making up the kit.

- Extensions for Ø 80/125 horizontal kit (Fig. 20). The kit with this configuration can be extended up to a *max. length of 32 m*, including the terminal with grid and excluding the concentric bend leaving the boiler. If additional components are assembled, the length equivalent to the maximum allowed must be subtracted. In this case the special extensions must be requested.

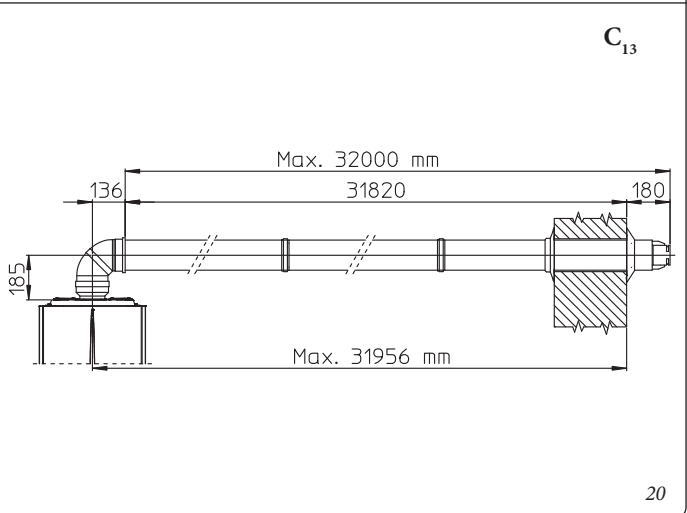
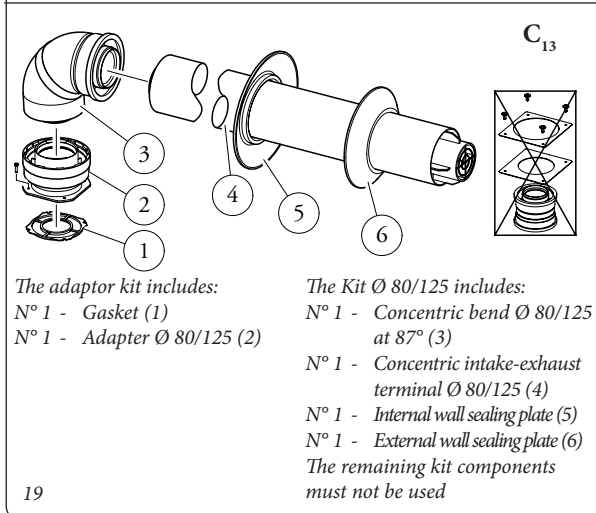
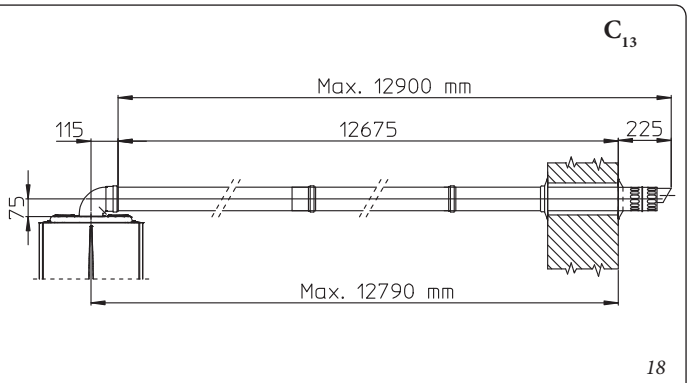
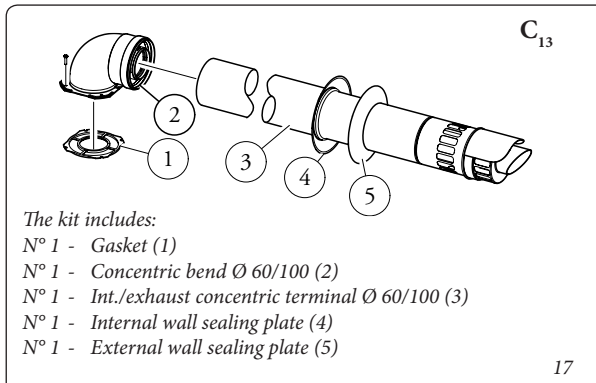

1.16 CONCENTRIC VERTICAL KIT INSTALLATION.

Type C configuration, sealed chamber and fan assisted.

Concentric vertical intake and exhaust kit. This vertical terminal is connected directly to the outside of the building for air intake and flue gas exhaust.

N.B.: the vertical kit with aluminium tile enables installation on terraces and roofs with a maximum slope of 45% (approx 25°) and the height between the terminal cap and half-shell (374 mm for Ø 60/100 and 260 mm for Ø 80/125) must always be observed.

Vertical kit with aluminium tile Ø 60/100.

Kit assembly (Fig. 21): install the concentric flange (2) on the central hole of the boiler, positioning gasket (1) with the circular projections downwards in contact with the boiler flange, and tighten using the screws contained in the kit. Installation of the fake aluminium tile: replace the tiles with the aluminium sheet (4), shaping it to ensure that rainwater runs off. Position the fixed half-shell (6) on the aluminium tile and insert the intake-exhaust pipe (5). Fit the

Ø 60/100 (3) concentric terminal pipe with the male side (5) (smooth) into the flange (2) up to the end stop; making sure that the wall sealing plate has been fitted (3), this will ensure sealing and joining of the elements making up the kit.

N.B.: when the boiler is installed in areas where very cold temperatures can be reached, a special anti-freeze kit is available that can be installed as an alternative to the standard kit.

- Extensions for vertical kit Ø 60/100 (Fig. 22). The kit with this configuration can be extended to a max. straight vertical length of 14.4 m, including the terminal. This configuration corresponds to a resistance factor of 100. In this case specific extensions must be requested.

Vertical kit with aluminium tile Ø 80/125.

Kit assembly (Fig. 23): to install the kit Ø 80/125 one must use the flanged adaptor kit in order to install the flue system Ø 80/125. Install the flanged adaptor (2) on the central hole of the boiler, positioning gasket (1) with the circular projections downwards in contact with the boiler flange, and tighten using the screws contained in the kit. Installation of the fake aluminium tile: replace the tiles with the aluminium sheet

(4), shaping it to ensure that rainwater runs off. Position the fixed half-shell (5) on the aluminium tile and insert the intake-exhaust pipe (7). Fit the Ø 80/125 concentric terminal pipe with the male side (smooth) to the female side of the adapter (1) (with lip gaskets) up to the end stop; making sure that the wall sealing plate (3) has been fitted, this will ensure sealing and joining of the elements making up the kit.

- Extensions for vertical kit Ø 80/125 (Fig. 24). The kit with this configuration can be extended up to a max. length of 32 m including the terminal. If additional components are assembled, the length equivalent to the maximum allowed must be subtracted. In this case specific extensions must be requested.

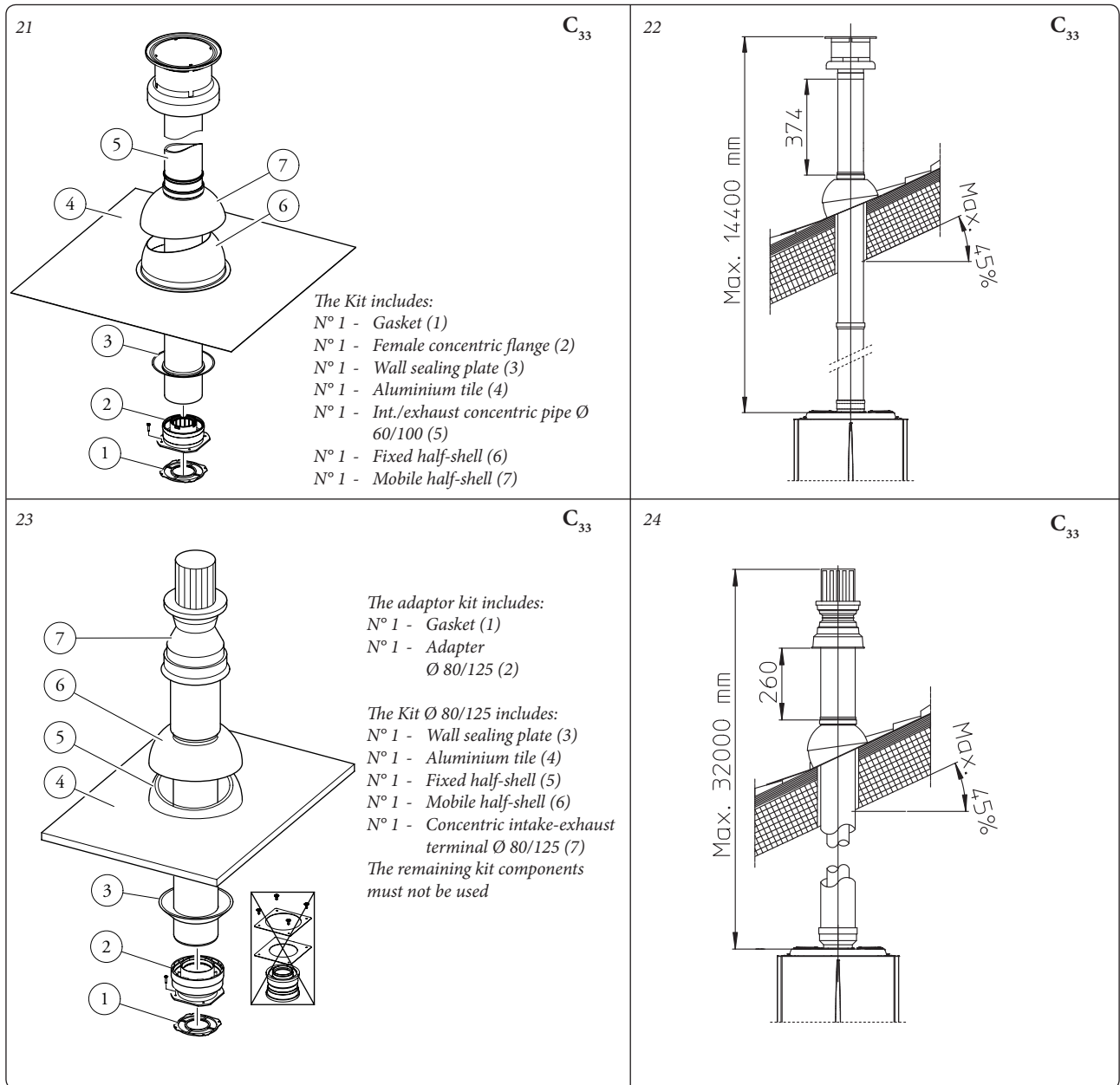

1.17 SEPARATOR KIT INSTALLATION.
Type C configuration, sealed chamber and fan assisted.

Separator kit Ø 80/80. This kit allows air to come in from outside the building and the exhaust to exit from the chimney, flue or intubated duct through divided flue exhaust and air intake pipes. Combustion products are expelled from pipe (S) (in plastic, so as to resist acid condensate). Air is taken in through duct (A) for combustion (this is also in plastic). The intake pipe (A) can be installed either on the right or left hand side of the central exhaust pipe (S). Both ducts can be routed in any direction.

- Kit assembly (Fig. 25): install flange (4) on the central hole of the boiler, positioning gasket (1) with the circular projections downwards in contact with the boiler flange, and tighten using the hex screws with flat tip contained in the kit. Remove the flat flange present in the lateral hole with respect to the central one (according to needs) and replace it with the flange (3), positioning the gasket (2) already present in the boiler and tighten using the supplied self-threading screws. Fit the male side (smooth) to the bends (5) in the female side of the flanges (3 and 4). Fit the intake terminal (6) with the male side (smooth) in the female side of the bend (5) up to the end stop, ensuring that the internal and external wall sealing plates are fitted. Fit the exhaust pipe (9) with the male end (smooth) to the female end of the bend

(5) up to the end stop; making sure that the internal wall sealing plate has been fitted, this will ensure sealing and joining of the elements making up the kit.

- Installation clearances (Fig. 26). The minimum installation clearance measurements of the Ø 80/80 separator terminal kit have been stated in some limit conditions.
- Extensions for separator kit Ø 80/80. The maximum vertical straight length (without bends) that can be used for Ø 80 intake and exhaust pipes is 41 metres, regardless from whether they are used for intake or exhaust. The maximum horizontal straight length (with bend in suction and in exhaust) that can be used for Ø 80 intake and exhaust pipes is 36 metres, regardless from whether they are used for intake or exhaust. Please note the type of installation C₄₃ must be done with a natural draught flue.

N.B.: to favour the removal of possible condensate forming in the exhaust pipe, tilt the pipes towards the boiler with a minimum slope of 1.5% (Fig. 27).

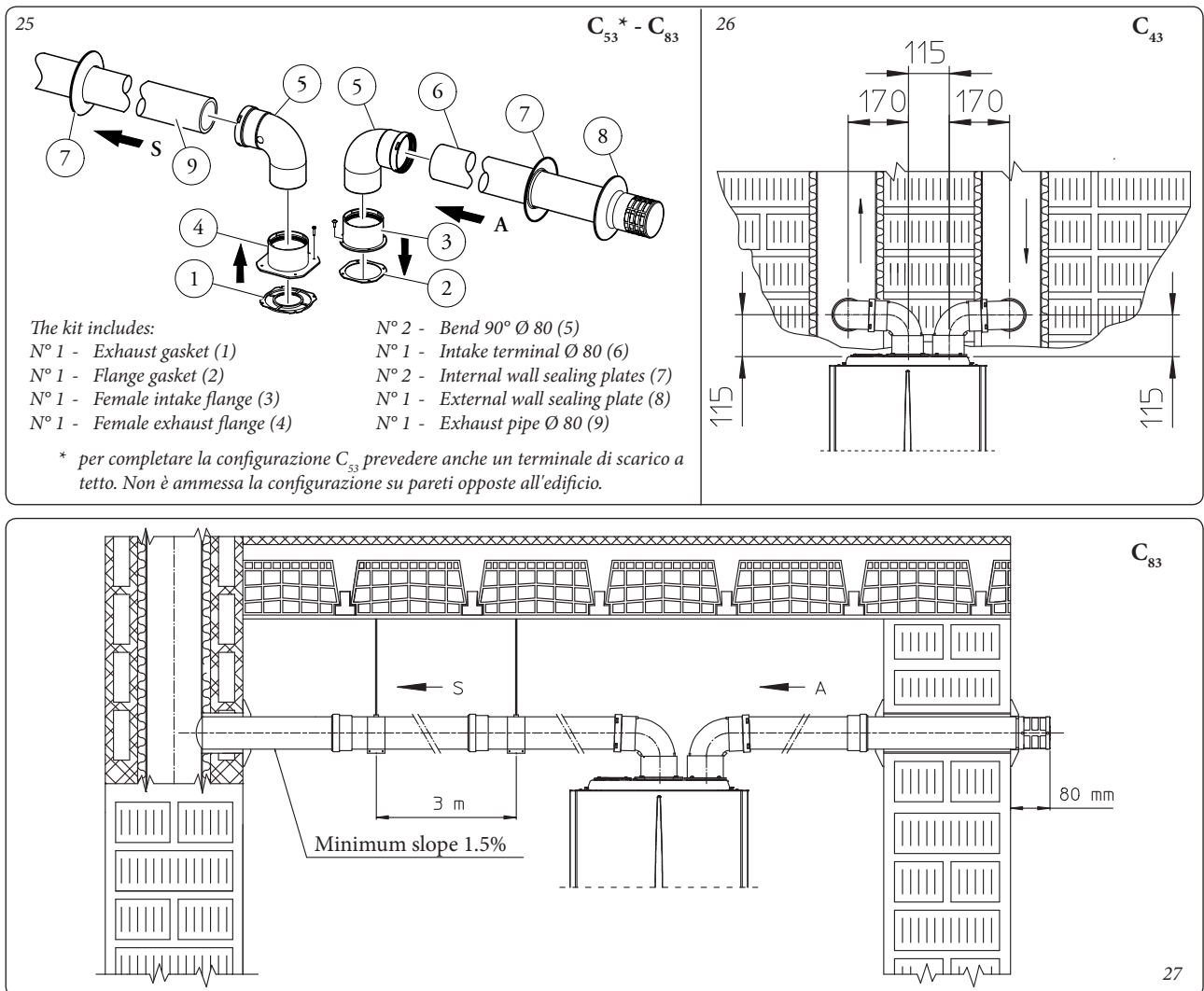

1.18 ADAPTOR C9 KIT INSTALLATION.

This kit allows an Immergas boiler to be installed in "C₉₃" configuration, with combustion air intake directly from the shaft where the flue gas exhaust is, obtained by means of a ducting system.

System composition.

The system must be combined with the following components (sold separately) to be functional and complete:

- kit C₉₃ Ø 100 or Ø125 version;
- rigid ducting Ø 60 and Ø 80 and flexible Ø 50 and Ø 80 kit;
- flue exhaust kit Ø 60/100 or Ø 80/125 configured according to the installation and type of boiler.

Kit Assembly.

- Mount the components of kit "C9" on the door (A) of the ducting system (Fig. 29).
- (Version Ø 125 only) mount the flanged adaptor (11) interposing the concentric gasket (10) on the boiler, fitting it with the screws (12).
- Mount the ducting system as described in the relative instructions sheet.
- Calculate the distances between the boiler drain and the bend of the ducting system.
- Prepare the boiler flue system, making sure that the internal pipe of the concentric kit is fitted up to the end stop in the ducting system curve (Quota "X" Fig. 30), whereas the external pipe must reach the end stop of the adaptor (1).

N.B.: to encourage the removal of possible condensate forming in the exhaust pipe, tilt the pipes towards the boiler with a minimum slope of 1.5%.

- Mount the cover (A) complete with adaptor (1) and caps (6) on the wall and assemble the flue system to the ducting system.

N.B.: (version Ø 125 only) before assembly check the gaskets are in the right position. In the event component lubrication (already carried out by the manufacturer) is not sufficient, remove the residual lubricant using a dry cloth, then to ease fitting coat the parts with common or industrial talc.

Once all components have been assembled properly, the exhaust fumes will be expelled via the ducting system; the combustion air for normal boiler operation will be aspirated directly by the shaft (Fig. 30).

Technical data.

- The dimensions of the shafts must ensure a minimum gap between the outer wall of the smoke duct and the inner wall of the shaft: 30 mm for circular section shafts and 20 mm in the event of a square section shaft (Fig. 28).
- Maximum 2 changes of direction are allowed on the vertical section of the flue system with a maximum clearance angle of 30° with respect to the vertical.

- The maximum vertical extension using a Ø 60 ducting system is 13 m, the maximum extension includes 1 bend Ø 60/10 at 90°, 1 m of horizontal pipe 60/100, 1 90° ducted bend Ø 60 and the roof terminal for ducting.

To determine the C₉₃ flue system in configurations other than that described (Fig. 30) one must consider that 1 metre of ducted pipe according to the indications described has a resistance factor equal to 4.9.

- The maximum vertical extension using a Ø 80 ducting system is 28 m, the maximum extension includes 1 adapter 60/100 to 80/125, 1 87° bend Ø 80/125, 1 m of horizontal pipe 80/125, 1 90° ducted bend Ø 80 and the roof terminal for ducting.

To determine the C₉₃ flue system in configurations other than that described (Fig. 30) one must consider the following pressure drops:

- 1 m of concentric pipe Ø 80/125 = 1 m of ducted pipe;
- 1 87° bend = 1.4 m of ducted pipe;

Consequently one must subtract the equivalent length of the part added to the 28 m available.

		Flexible Ø 50 and Rigid Ø 60 ducting (A) mm	SHAFT (B) mm	SHAFT (C) mm
		66	106	126
		Rigid Ø 80 ducting (A) mm	SHAFT (B) mm	SHAFT (C) mm
		86	126	146
		Flexible Ø 80 ducting (A) mm	SHAFT (B) mm	SHAFT (C) mm
		90	130	150

Kit composition:

Ref.	Qty	Description
1	1	Door adaptor Ø 100 or Ø 125
2	1	Door gasket made of neoprene
3	4	Screws 4.2 x 9 AF
4	1	Hex headed screw M6 x 20
5	1	Flat nylon washer M6
6	2	Door hole closure metal-sheet plate plug
7	1	Plug gasket made of neoprene
8	1	Toothed washer M6
9	1	Nut M6
10	1 (kit 80/125)	Concentric gasket Ø 60-100
11	1 (kit 80/125)	Flanged adapter Ø 80-125)
12	4 (kit 80/125)	Hex headed screws M4 x 16 slotted
-	1 (kit 80/125)	Bag of lubricating talc

Supplied separately:

Ref.	Qty	Description
A	1	Ducting kit door

Installation drawings key:

- 1** Unique identification of the component in the kit
- A** Identification of the component not supplied in this kit

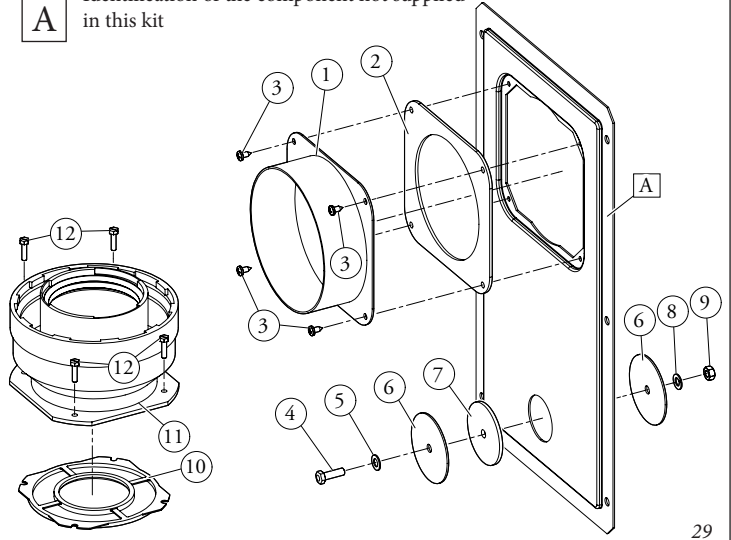

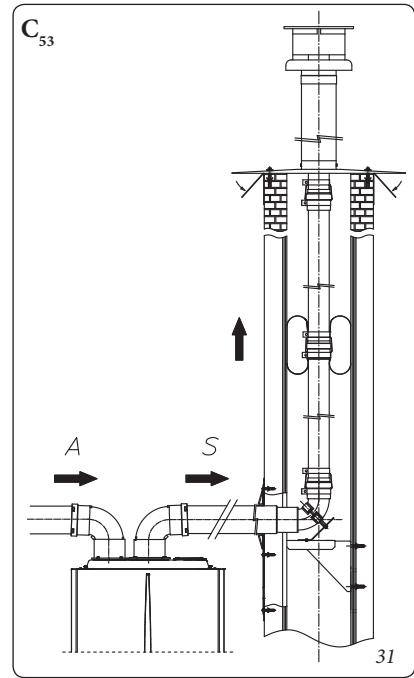
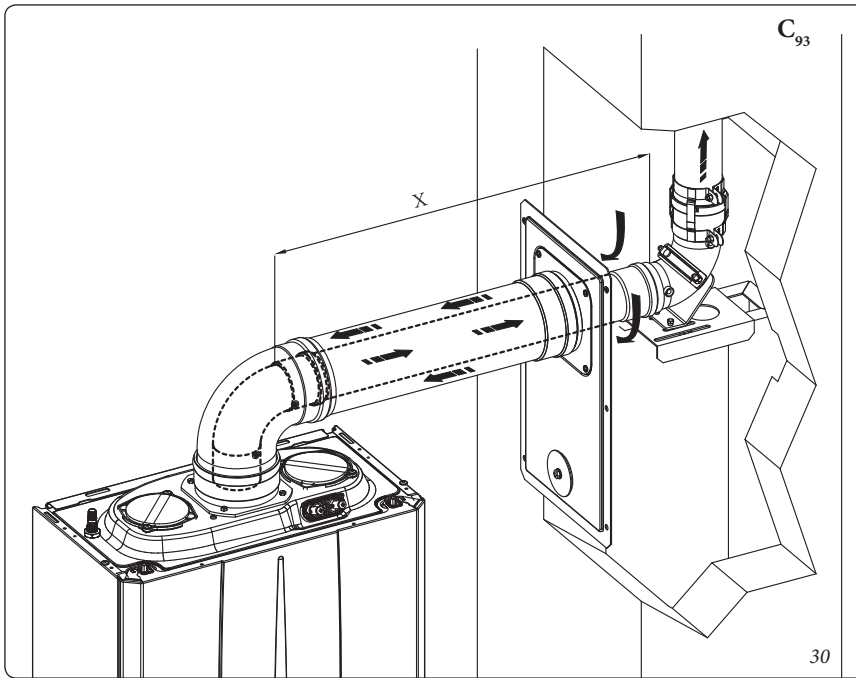

1.19 DUCTING OF FLUES OR TECHNICAL SLOTS.

Ducting is an operation through which, via the introduction of one or more relevant pipes, one achieves a system for the evacuation of the combustion products of a gas appliance, made up from the coupling of an existing or new ducting pipe with a chimney, flue or technical slot (also in new buildings) (Fig. 31). Ducting requires ducts declared to be suitable for the purpose by the manufacturer, following the installation and user instructions, provided by the manufacturer and the requirements of the standards in force.

Immergas ducting system. The $\varnothing 60$ rigid, $\varnothing 80$ flexible and $\varnothing 80$ rigid "Green Range" ducting systems must only be used for domestic use and with Immergas condensing boilers.

In any case, ducting operations must respect the provisions contained in the standard and in current technical regulations; in particular, the declaration of conformity must be compiled at the end of work and on commissioning of the ducted system. The instructions in the project or technical report must likewise be followed, in cases provided for by the standard and current technical regulations. The system or components of the system have a technical life complying with current standards, provided that:

- it is used in average atmospheric and environmental conditions, according to current regulations, (absence of flue gas, dusts or gases that can alter the normal thermophysical or chemical conditions; existence of temperatures coming within the standard range of daily variation, etc.).
- Installation and maintenance must be performed according to the indications supplied by the manufacturer and in compliance with the regulations in force.

- The maximum length specified by the manufacturer must be respected; in this regard:
 - The max. possible length of the $\varnothing 60$ flexible ducting vertical section is equal to 22 m. This length is obtained considering the complete $\varnothing 80$ exhaust terminal, 1m of $\varnothing 80$ pipe in exhaust, two $90^\circ \varnothing 80$ bends at boiler outlet.
 - The max. possible length of the $\varnothing 80$ flexible ducting vertical section is equal to 30 m. This length is obtained considering the $\varnothing 80$ complete exhaust terminal, 1m of $\varnothing 80$ pipe in exhaust, two $90^\circ \varnothing 80$ bends at boiler outlet for connecting to the ducting system and two direction changes of the flexible hose inside the chimney/technical slot.
 - The max. possible length of the $\varnothing 80$ flexible ducting vertical section is equal to 30 m. This length is obtained considering the complete $\varnothing 80$ exhaust terminal, 1m of $\varnothing 80$ pipe in exhaust, two $90^\circ \varnothing 80$ bends at boiler outlet.

You can also install an additional $\varnothing 50$ flexible ducting system the specifications of which are found on the relevant instructions sheet inside the kit.

1.20 CONFIGURATION TYPE B, OPEN CHAMBER AND FAN ASSISTED FOR INDOORS.

The appliance can be installed inside buildings in B_{23} or B_{53} mode; in this case, all technical rules and national and local regulations in force, must be complied with.

- Type B open chamber boilers must not be installed in places where commercial, artisan or industrial activities take place, which use products that may develop volatile vapours or substances (e.g. acid vapours, glues, paints, solvents, combustibles, etc.), as well as dusts (e.g. dust deriving from the working of wood, coal fines, cement, etc.), which may be damaging for the components of the appliance and jeopardise functioning.

- in B_{23} and B_{53} configuration, unless otherwise provided for by local regulations, the boilers must not be installed in bedrooms, bathrooms or in studio flats. They must neither be installed in rooms containing solid fuel heat generators nor in rooms communicating with said rooms.
- Installation of appliances in B_{23} and B_{53} configuration is recommended in non-residential premises and which are permanently ventilated.

For installation the cover kit must be used, referred to in Paragraph 1.13.

1.21 FLUE EXHAUST TO FLUE/CHIMNEY.

Flue exhaust does not necessarily have to be connected to a branched type traditional flue. The flue exhaust, for boiler clots installed in C configuration, can be connected to a special LAS type multiple flue. For B_{23} configurations, exhaust is only allowed into individual chimney or directly into the external atmosphere via a relevant terminal. The multiple flues and the combined flues must also only be connected to type C appliances of the same type (condensation), having nominal heat inputs that do not differ by more than 30% less with respect to the maximum that can be attached and powered by the same fuel. The thermo-fluid dynamic features (flue flow rate, % of carbon dioxide, % humidity etc...) of the appliances attached to the same multiple flues or combined flues, must not differ by more than 10% with respect to the average boiler attached. Multiple and combined flues must be specially designed according to the calculation method and requirements of the technical standards in force, by a professionally qualified company. Chimney or flue sections for connection of the flue exhaust pipe must comply with requisites of technical standards in force.

INSTALLER

USER

MAINTENANCE TECHNICIAN

1.22 FLUES, CHIMNEYS AND CHIMNEY CAPS.

The flues, chimneys and chimney caps for the evacuation of combustion products must be in compliance with applicable standards. Chimneys and roof-installed exhaust terminals must comply with the outlet height and with the distance from technical volumes set forth by the technical standards in force.

Positioning the wall flue exhaust terminals. The wall flue exhaust terminals must:

- be installed on external perimeter walls of the building;
- be positioned according to the minimum distances specified in current technical standards.

Combustion products exhaust of natural draught or fan assisted appliances in open-top closed environments. In spaces closed on all sides with open tops (ventilation pits, courtyards etc.), direct combustion product exhaust is allowed for natural draught or fan assisted gas appliances with a heat input range from 4 to 35 kW, provided the conditions as per the current technical standards are respected.

1.23 WATER TREATMENT SYSTEM FILLING.

As already mentioned in the previous paragraphs, a treatment of the thermal and domestic system water is required, in compliance with the local standards in force.

The parameters that influence the duration and proper operation of the heat exchanger are the water's PH, hardness, conductivity, and oxygen, together with the system's processing residues (any welding residues), any oil present and corrosion products that can, in turn, cause damage to the heat exchanger.

In order to prevent this from happening, you are recommended to:

- Before installation on new systems as well as old ones, clean the system with clean water to eliminate solid residues contained therein.
- Clean the system with a chemical treatment:
 - Clean the new system with a suitable cleaning device (for example Sentinel X300, Fernox Cleaner F3 or Jenaqua 300) combined with thorough washing.
 - Clean the old system with a suitable cleaning device (for example Sentinel X400 or X800, Fernox Cleaner F3 or Jenaqua 400) combined with thorough washing.

- Check the maximum hardness and quantity of filling water referring to the graphics (Fig. 32). If the contents and hardness of the water are below the indicated curve, no specific treatment is required; otherwise, to limit the content of calcium carbonate, you must provide for water-filling treatment.

- Should you be required to provide for water treatment, this should be carried out by completely desalinating the filling water. As opposed to the complete softening process, desalinating the water completely not only removes hardening agents (Ca, Mg), but also eliminates all other minerals to reduce water-filling conductivity up to 10 microsiemens/cm. Given its low conductivity, desalinated water does not only prevent the formation of lime scale, but also serves as protection against corrosion.

- Insert a suitable inhibitor / passivator (for example Sentinel X100, Fernox Protector F1, or Jenaqua 100); if required, also insert appropriate antifreeze (such as for example Sentinel X500, Fernox Alphi 11 or Jenaqua 500).

- Check electrical conduction of the water, which should be higher than 2000 $\mu\text{s}/\text{cm}$ in the case of treated water and lower than 600 $\mu\text{s}/\text{cm}$ in the case of non-treated water.

- To prevent corrosion, the water system's PH should be between 7.5 and 9.5.

- Check the maximum content of chlorides, which should be less than 250 mg/l.

N.B.: for quantities and methods of use of water-treatment products, refer to the instructions provided by their manufacturer.

1.24 SYSTEM FILLING.

Once the boiler is connected, proceed with system filling via the filling cock (Part. 24 Fig. 34). Filling is performed at low speed to ensure release of air bubbles in the water via the boiler and central heating system vents.

The boiler has a built-in automatic venting valve on the pump. *Check if the cap is loose.* Open the radiator vent valves.

Close radiator vent valves when only water escapes from them.

Close the filling valve when the boiler pressure gauge indicates approx. 1.2 bar.

N.B.: during these operations, enable the automatic vent functions on the boiler (active on first ignition).

1.25 FILLING THE CONDENSATE DRAIN TRAP.

On first lighting of the boiler, flue gas may come out the condensate drain; after a few minutes' operation check that this no longer occurs. This means that the drain trap is filled with condensate to the correct level preventing the passage of flue gas.

1.26 GAS SYSTEM START-UP.

To start up the system, refer to the technical standard in force:

In particular, for new gas systems:

- open windows and doors;
- avoid presence of sparks or naked flames;
- bleed all air from pipelines;
- ensure the internal system is properly sealed according to the specifications set forth by technical regulations in force.

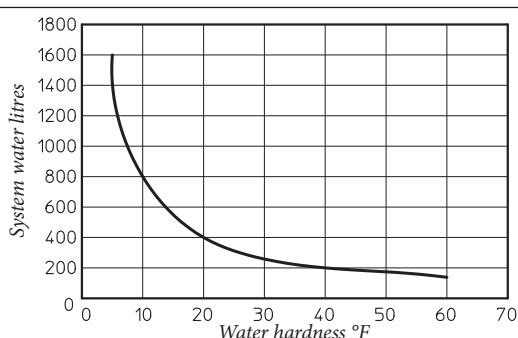

N.B.: the graph refers to the entire life cycle of the system. Therefore, also consider scheduled and unscheduled maintenance, which involves emptying and filling the said system.

1.27 BOILER START-UP (IGNITION).

To commission the boiler (the operations listed below must only be performed by qualified personnel and in the presence of staff only):

- check that the internal system is properly sealed according to the regulations in force;
- ensure that the type of gas used corresponds to the boiler settings (the type of gas appears on the display on first electrical supply voltage, or by checking the relative parameter "G");
- check connection to a 230V-50Hz power mains, correct L-N polarity and earthing connection;
- Check that there are external factors that may cause the formation of fuel pockets;
- switch the boiler on and ensure correct ignition;
- make sure that the gas flow rate and relevant pressure values comply with those given in the manual (*Par. 3.20*);
- ensure that the safety device is engaged in the event of gas supply failure and check activation time;
- check the intervention of the main switch located upstream from the boiler and in the boiler;
- check that the intake and/or exhaust terminals (if fitted) are not blocked.
- Carry out the flue test.

The boiler must not be started up even if only one of the checks should be negative.

1.28 CIRCULATION PUMP.

The boilers are supplied with a variable speed circulator pump.

In the central heating mode, the following operating modes are available and can be selected from the "P.C.B. programming" menu.

N.B.: the $\Delta T(A3)$ can be controlled compatibly with the characteristics of the central heating system and of the boiler.

- **Proportional head (A3 = 0):** the circulator speed varies according to the power emitted by the burner, the greater the power the greater the speed.
- **ΔT Constant (A3 = 5 ÷ 25 K):** the pump speed varies to maintain the ΔT constant between the system flow and return according to set value K (A3 = 15 Default).
- **Fixed:** by setting parameters "A1" and "A2" at the same value (5/6 ÷ 9), the pump operates at constant speed. For the boiler to work properly, it is not allowed to drop below the minimum value set out above.

In domestic hot water mode, the circulator pump always runs at full speed.

Pump release. If, after a prolonged period of inactivity, the circulation pump is blocked, turn the motor shaft using a screwdriver. Take great care during this operation to avoid damage to the motor.

By-pass Regulation (Part. 21 Fig. 34). The boiler leaves the factory with the bypass open.

If necessary, the by-pass can be regulated to system requirements from minimum (by-pass closed) to maximum (by-pass open). Adjust using a flat-head screwdriver. Turning clockwise opens the bypass and anticlockwise closes it.

Total head available to the system.

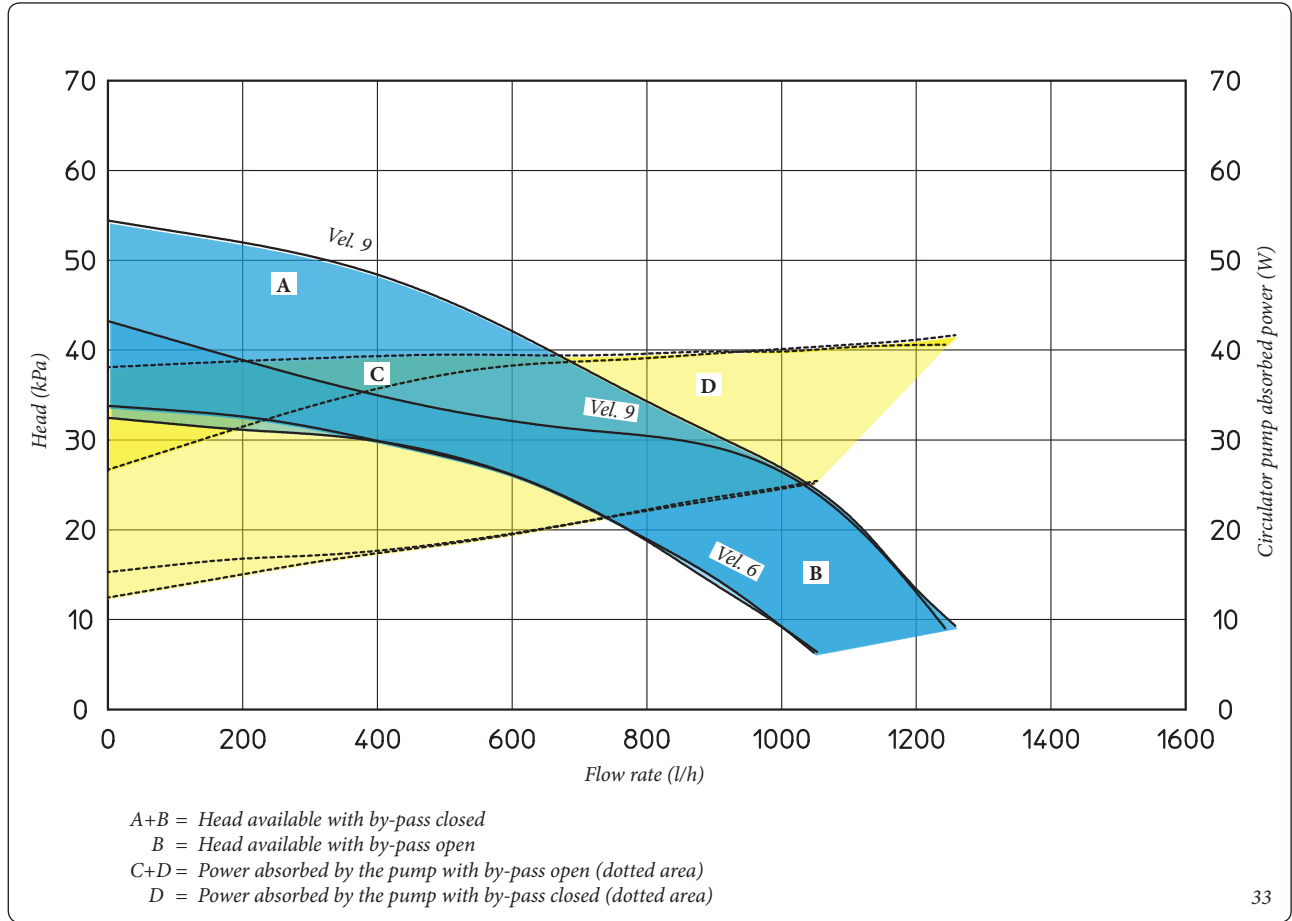

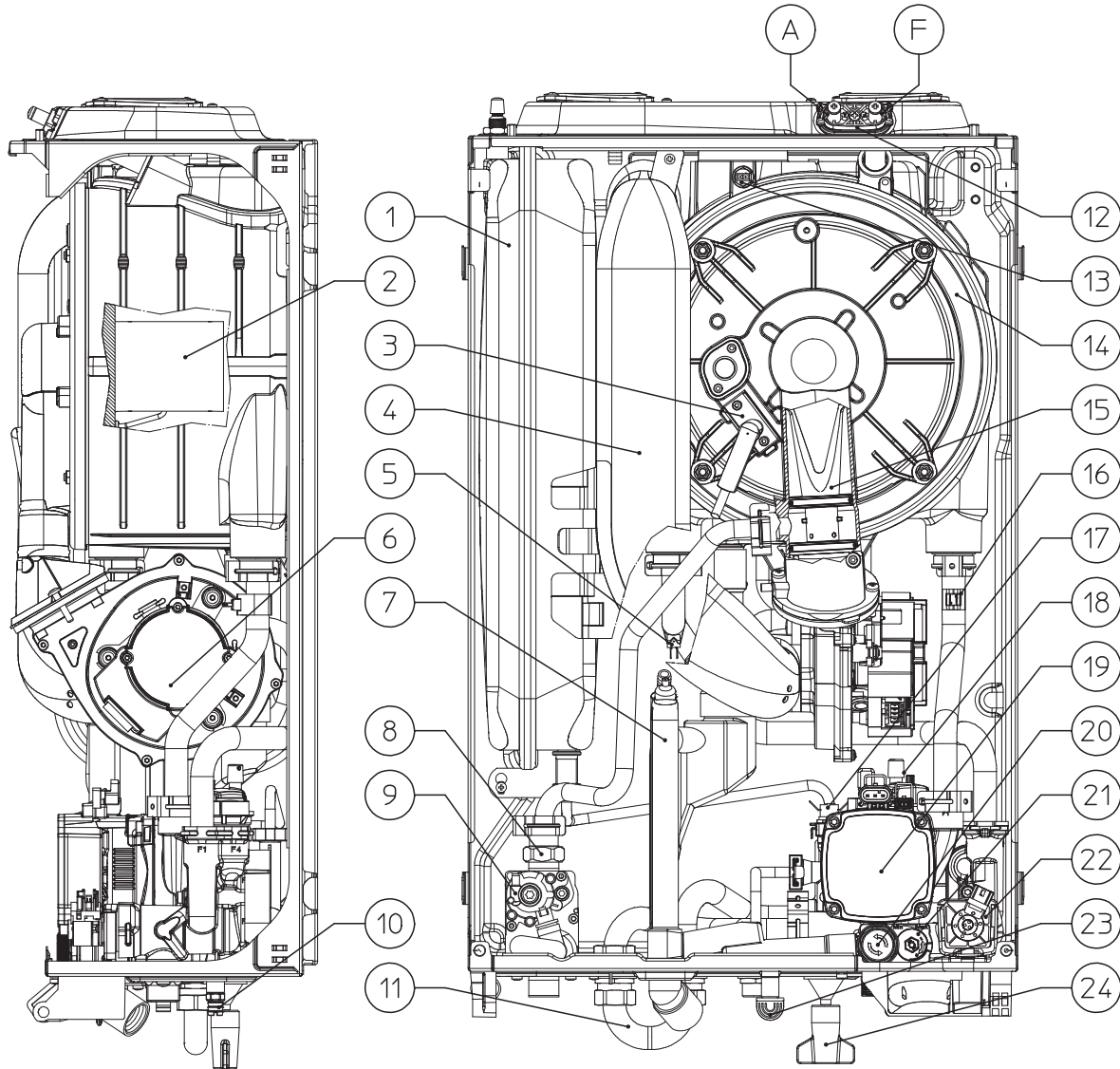

Key:

- 1 - System expansion vessel
- 2 - Burner
- 3 - Ignition/detection electrode
- 4 - Air intake pipe
- 5 - Flow probe
- 6 - Fan
- 7 - Condensate drain trap
- 8 - Gas nozzle

- 9 - Gas valve
- 10 - System draining valve
- 11 - Storage tank return flow by-pass
- 12 - Sample points (air A) - (flue gases F)
- 13 - Flue probe
- 14 - Condensation module
- 15 - Venturi
- 16 - Return probe
- 17 - System pressure switch

- 18 - Air vent valve
- 19 - Boiler pump
- 20 - 3 bar safety valve
- 21 - By-pass
- 22 - 3-way valve (motorised)
- 23 - Valve drain fitting signal
- 24 - System filling valve

1.30 KITS AVAILABLE ON REQUEST.

• System cut-off valve kits with or without inspectionable filter (on request) The boiler is designed for installation of system interception cocks to be placed on flow and return pipes of the connection assembly. This kit is very useful for maintenance because it allows to empty just the boiler without having to empty the entire system. Moreover, the version with filter preserves the functioning characteristics of the boiler thanks to its inspectionable filter.

- Cover kit (on request). If installed outdoors in a partially protected place with direct air intake, it is compulsory to mount the appropriate top protection cover for the correct functioning of the boiler and to protect it from adverse weather conditions.
- Cycloidal filter kit (on request). The magnetic cycloidal filter is able to detect the ferrous residues present in the system's water. Thanks to the two cocks in the kit, it facilitates maintenance by cleaning the filter without having to empty the circuit.

The above-mentioned kits are supplied complete with instructions for assembly and use.

INSTALLER

USER

MAINTENANCE TECHNICIAN

2 USE AND MAINTENANCE INSTRUCTIONS.

2.1 CLEANING AND MAINTENANCE.

Attention: to preserve the boiler's integrity and keep the safety features, performance and reliability which distinguish it unchanged over time, maintenance operations must be carried out on a yearly basis in compliance with that stated in the "annual check and maintenance of the appliance" section, in compliance with national, regional, or local standards in force.

2.2 GENERAL WARNINGS.

Never expose the wall-mounted boiler to direct vapours from a cooking surface.

Use of the boiler by unskilled persons or children is strictly prohibited.

For safety purposes, check that the air intake/ flue exhaust terminals (if fitted) are not blocked. If temporary shutdown of the boiler is required, proceed as follows:

- a) drain the heating system if anti-freeze is not used;
- b) shut-off all electrical, water and gas supplies.

In the case of work or maintenance to structures located in the vicinity of ducting or devices for flue extraction and relative accessories, switch off the appliance and on completion of operations ensure that a qualified technician checks efficiency of the ducting or other devices. Never clean the appliance or connected parts with easily flammable substances. Never leave containers or flammable substances in the same environment as the appliance.

• **Attention:** using any components that use electrical power requires some fundamental rules to be observed:

- do not touch the appliance with wet or moist parts of the body; do not touch when bare-foot;
- never pull electrical cables or leave the appliance exposed to atmospheric agents (rain, sunlight, etc.);
- the appliance power cable must not be replaced by the user;
- in the event of damage to the cable, switch off the appliance and contact exclusively qualified staff for replacement;
- if the appliance is not to be used for a certain period, disconnect the main power switch.

N.B.: the temperatures indicated by the display have a tolerance of +/- 3°C due to environmental conditions that cannot be attributed to the boiler.

At the end of its service life, the appliance must not be disposed of like normal household waste nor abandoned in the environment, but must be removed by a professionally authorised company. Contact the manufacturer for disposal instructions.

2.3 CONTROL PANEL.















Key:

<p>1 - Off/Stand-by/Summer/Winter button</p> <p>2 - Information buttons</p> <p>3 - Reset Button</p> <p>4 - (*) Button to reduce the domestic hot water temperature</p> <p>5 - (*) Button to increase the domestic hot water temperature</p> <p>6 - Button to increase the system water flow temperature</p> <p>7 - Button to decrease the system water flow temperature</p> <p>8 - Boiler manometer</p> <p>9 - (*) DHW production phase function active</p> <p>10 - Boiler connected to remote control V² (optional) or to other external devices</p> <p>11 - Flame presence symbol and relative output scale</p>	<p>12 - Operation with external temperature probe active (optional)</p> <p>13 - Solar function active</p> <p>14 - Central heating room mode function active</p> <p>15 - Central heating temperature level indicator</p> <p>16 - Boiler in Stand-by mode</p> <p>17 - Operation in winter mode</p> <p>18 - (*) Operation in summer mode</p> <p>19 - Temperature indicator, boiler info and error codes</p> <p>20 - Not used on this model</p> <p>21 - Blocked boiler, it needs to be unblocked by pressing the "RESET" button</p> <p>22 - D.H.W. temperature level indicator</p>
--	--

(*) N.B.: (when the boiler is connected to an external storage tank unit)

2.4 USING THE BOILER.

Before ignition make sure the heating system is filled with water and that the manometer (8) indicates a pressure of 1 ÷ 1.2 bar.



- Open the gas cock upstream from the boiler.
- Press the button “  ” repeatedly to cyclically switch from “stand-by” () to “summer” () and “winter” () mode.
- **Summer** (): in this mode the boiler functions only to produce the DHW, the temperature is set via the buttons “ ” and the relative temperature is shown on the display via the indicator (19). Moreover, the temperature level that can be selected is shown on the indicator (22).
- **Winter** (): in this mode the boiler works both for producing domestic hot water and for central heating. The DHW temperature is always regulated via the buttons “ ”, the central heating temperature is regulated via the buttons “ ” and the relative temperature is shown on the display via the indicator (19). Moreover, the temperature level that can be selected is shown on the indicator (15).

From this moment the boiler functions automatically. With no demand for heat (central heating or domestic hot water production) the boiler goes to “standby” function, equivalent to the boiler being powered without presence of flame. Each time the burner ignites, the relative flame present symbol is displayed (11) with relative output scale.



- **Operation with Comando Amico Remoto remote control v2 (CAR^{v2}) (Optional).** If the CAR^{v2} is connected, the () symbol will appear on the display. The boiler regulation parameters can be set via the CAR^{v2} control panel and the reset button (3) remains active on the boiler control panel, along with the switch-off button (1) (“off” mode only) and the display where the functioning state is shown.

Caution: if the boiler is switched “off” the CAR^{v2} will display the connection error symbol “ERR>CM”, the CAR^{v2} is however powered constantly so as not to lose the stored programs.





- **Solar operating mode** (). This function is activated automatically if the boiler detects a probe on the DHW inlet (optional) or if the “Solar ignition delay” parameter is more than 0 seconds.

During a withdrawal, if the outlet water is hot enough or if there is “Solar ignition delay” time, the boiler does not switch on, the D.H.W. withdrawal symbol () appears on the display along with the flashing solar function symbol ()



When the water supplied by the solar system is at a temperature lower than what is set, or if the “Solar ignition delay” time has elapsed, the boiler switches on. At this point, the solar function symbol remains permanently on.

- **Operation with optional external probe** (). In the case of a system with optional external probe, the boiler flow temperature for room central heating is managed by the external probe depending on the external temperature measured (Par. 1.10). The flow temperature can be modified by selecting the functioning curve via the buttons “ ” (or on the CAR^{v2} control panel, if connected to the boiler) selecting a value from “0 to 9”.

With external probe present, the relative symbol (12) will appear on the display. In the central heating mode, if the temperature of the water contained in the system is sufficient to heat the radiators, the boiler can only function with the activation of the pump.

- **“Stand-by” mode.** Press button “  ” repeatedly until the symbol () appears. From now on the boiler remains inactive and the antifreeze function, pump anti-block function and 3-way and signalling of any anomalies is guaranteed.

N.B.: in these conditions the boiler is still powered.

- **“Off” mode.** By holding the button “  ” down for 8 seconds, the display switches-off and the boiler is off completely. The safety functions are not guaranteed in this mode.

N.B.: while not having functions active, in these conditions the boiler must be considered still live. This state is displayed by a “dot” lit in the centre of the display.

- **Display functioning.** The display lights up while the control panel is being used; after a set inactivity period, the brightness drops until only the active symbols are displayed. The lighting mode can be varied via parameter “t8” in the P.C.B. programming menu.

2.5 FAULT AND ANOMALY SIGNALS.

The Victrix Tera Plus boiler reports any anomalies via a code shown on the boiler display (19) according to the following table:

Error Code	Anomaly signalled	Cause	Boiler status / Solution
01	No ignition block	In the event of request of room central heating or domestic hot water production, the boiler does not switch on within the preset time. Upon appliance commissioning or after extended downtime, it may be necessary to eliminate the block.	Press the Reset button (1)
02	Safety thermostat block (over-temperature)	During normal operation, if a fault causes excessive overheating internally, the boiler goes into overheating block.	Press the Reset button (1)
03	Flue safety thermostat block	During normal operation, if a fault causes excessive flue gas overheating, the boiler blocks	Press the Reset button (1)
04	Contacts resistance block	The P.C.B. detects a fault on the gas valve supply. Check its connection. (the anomaly is detected and displayed only in the event of a request).	Press the Reset button (1)
05	Flow probe anomaly	The board detects an anomaly on the flow NTC probe.	The boiler does not start (1)
08	Maximum N° of resets	Number of allowed resets that have already performed.	Attention: the fault may be reset up to 5 times consecutively, after which the function is inhibited for at least one hour. One attempt is gained every hour for a maximum of 5 attempts. By switching the appliance on and off again, the 5 attempts are re-acquired.
10	Insufficient system pressure	Water pressure inside the central heating circuit that is sufficient to guarantee the correct operation of the boiler is not detected.	Check on the boiler pressure gauge (1) that the system pressure is between 1÷1.2 bar and restore the correct pressure if necessary.
12	Storage tank probe anomaly	The board detects an anomaly on the storage tank probe	The boiler cannot produce domestic hot water (1)
15	Configuration error	If the board detects an anomaly or incongruity on the electric wiring, the boiler will not start.	If normal conditions are restored the boiler restarts without having to be reset. Check that the boiler is configured correctly (1)
16	Fan anomaly	This occurs if the fan has a mechanical or electrical fault.	Press the Reset button (1)
20	Parasite flame block	This occurs in the event of a leak on the detection circuit or anomaly in the flame control unit.	Press the Reset button (1)
23	Return probe anomaly	The board detects an anomaly on the return NTC probe	The boiler does not start (1)
24	Push button control panel anomaly	The board detects an anomaly on the pushbutton panel.	If normal conditions are restored the boiler restarts without having to be reset (1).
27	Insufficient circulation	This occurs if there is overheating in the boiler due to insufficient water circulating in the primary circuit; the causes can be: - low system circulation; check that no shut-off devices are closed on the heating circuit and that the system is free of air (deaerated); - circulating pump blocked; free the circulating pump.	Press the Reset button (1).
29	Flue probe anomaly	The board detects an anomaly on the flue gas probe	The boiler does not start (1)
31	Loss of remote control communication.	This occurs if an incompatible remote control is connected, or if communication between the boiler and the remote control is lost	Disconnect and reconnect the power to the boiler. If the Remote Control is still not detected on re-starting, the boiler will switch to local operating mode, i.e. using the controls on the control panel. In this case the "Central Heating" (1) function cannot be activated.
37	Low power supply voltage	This occurs when the power supply voltage is lower than the allowed limits for the correct boiler operation.	If normal conditions are restored the boiler restarts without having to be reset (1)
38	Loss of flame signal	This occurs when the boiler is ignited correctly and the burner flame switches off unexpectedly; a new attempt at ignition is performed and if normal conditions are restored, the boiler does not have to be reset.	If normal conditions are restored the boiler restarts without having to be reset (1) (2)
43	Block due to loss of flame signal	This occurs if the "Flame signal loss" error occurs many times in a row within a preset period (38).	Press the Reset button, before restarting, the boiler will run a post-ventilation cycle. (1)

(1) If the block or anomaly persists, contact an authorised company (e.g. Authorized Technical After-Sales Service).

(2) The anomaly can only be verified in the list of errors in the "Information" menu

Error Code	Anomaly signalled	Cause	Boiler status / Solution
45	High ΔT	The boiler detects a sudden, unexpected increase in the ΔT between the flow probe and the system return probe.	The power of the burner is limited to prevent damage to the condensation module and once the right ΔT is restored, the boiler resumes regular operation. Make sure there is water circulating in the boiler, that the pump is configured according to system requirements and that the return probe works properly. (1) (2)
47	Burner power limitation	Should flue high temperature be detected, the boiler reduces power supplied so as not to damage it.	(1)
51	CAR Wireless communication failure	If there is no communication between the boiler and Wireless version CAR, an anomaly is signalled. From this moment, it is only possible to control the system by means of the control panel of the boiler itself.	Check operation of the Wireless CAR, check the battery charge (refer to the relative instructions booklet).
60	Anomaly pump blocked	The pump is stopped due to one of the following causes: Impeller blocked, electrical fault.	Try to unblock the pump as described in the relative section. If normal conditions are restored the boiler restarts without having to be reset (1)
61	Air in circulator pump	Air is detected inside the pump; the pump cannot work.	Vent the pump and the central heating circuit. If normal conditions are restored the boiler restarts without having to be reset (1)
70	Return/flow probe exchange	In case of an incorrect boiler wiring connection the error is detected	The boiler does not start (1)
75	Return and/or flow probe malfunction	Possible failure of one or both system return and flow probes	The boiler does not start (1)
76	Return and/or flow probes temperature drift	A malfunction of one or both system return and flow probes is detected	The boiler does not start (1)
<p>(1) If the block or anomaly persists, contact an authorised company (e.g. Authorized Technical After-Sales Service).</p> <p>(2) The anomaly can only be verified in the list of errors in the “Information” menu</p>			

INSTALLER

USER

MAINTENANCE TECHNICIAN

2.6 INFORMATION MENU.

By pressing the button “INFO”, the “Information menu” is activated for at least 1 second, displaying some boiler operating parameters.

To scroll through the various parameters, press the buttons “DHW regulation”  .

With the menu active on the indicator (19) the parameter via the letter “d” plus the number of the parameter that is being displayed will alternately show.

To view the parameter value, select it by pressing the button .

Press “RESET” or wait 15 minutes to go back to the previous screen or exit the menu.

Id Parameter	Description
d 0.0	Not used
d 0.1	Displays the flame signal (uA)
d 0.2	Displays the primary exchanger output instant heating flow temperature
d 0.3	Not used
d 0.4	Displays the values set for central heating set
d 0.5	Displays the values set for DHW set
d 0.6	Displays the external environment temperature (if optional external probe present) If the temperature is below zero, the value is displayed flashing.
d 0.7	Displays the storage tank unit temperature
d 0.8	Displays the system return water temperature
d 0.9	Displays the list of the last eight anomalies. (to scroll the list press the “central heating temperature regulation” buttons (6 and 7))
d 1.0	Anomaly list reset. Once “d 1.0” is displayed, press the Reset button for at least 3 seconds; deletion is confirmed via the “88” symbols flashing for two seconds
d 1.1	Not used
d 1.2	Displays the pump operating speed
d 1.3	Not used
d 1.4	Displays the pump flow rate (lh/100)
d 1.5	Displays the fan operating speed (rpm/100)
d 1.6	Displays the temperature read on the flue probe
d 1.7	Displays the calculated flow temperature
d 1.8	At the end of the screed heater function, displays for how many hours the flow temperature remained at “Top set”
d 1.9	Toggles between the safety software version and the functional software version
d 2.0	Displays the flow temperature of zone two (optional)
d 2.1	Displays the flow temperature of zone three (optional)
d 2.2	Not used

2.7 BOILER SHUTDOWN

Switch the boiler off by putting it in “off” mode, disconnect the onnipolar switch outside of the boiler and close the gas cock upstream from the appliance. Never leave the boiler switched on if left unused for prolonged periods.

2.8 RESTORE CENTRAL HEATING SYSTEM PRESSURE

Periodically check the system water pressure. The boiler pressure gauge should read a value of between 1 and 1.2 bar.

If pressure falls below 1 bar (with the circuit cold), restore normal pressure via the cock located at the bottom of the boiler (Part. 1 Fig. 6).

N.B.: close the valve after the operation.

If pressure values reach around 3 bar the safety valve may be activated.

In this case, remove water from a radiator air vent valve until a pressure of 1 bar is achieved, or ask for assistance from professionally qualified personnel.

In the event of frequent pressure drops, contact qualified staff for assistance to eliminate the possible system leakage.

2.9 DRAINING THE SYSTEM.

To drain the boiler, use the special draining valve (Fig. 6).

Before draining, ensure that the filling cock is closed.

2.10 ANTIFREEZE PROTECTION.

The “Victrix Tera Plus” series boiler features an antifreeze function that lights the burner automatically when the temperature falls below 4°C (standard protection down to min. temperature of -5°C). All information relative to the anti-freeze protection is stated in *Par. 1.3*. In order to guarantee the integrity of the appliance and the domestic hot water heating system in zones where the temperature falls below zero, we recommend the central heating system is protected using anti-freeze liquid and installation of the Immergas Anti-freeze Kit in the boiler. In the case of prolonged inactivity (second case), we also recommend that:

- the electric power supply is disconnected;
- the heating circuit and boiler domestic water circuit must be drained. In systems that are drained frequently, filling must be carried out with suitably treated water to eliminate hardness that can cause lime-scale.

2.11 CASE CLEANING.

Use damp cloths and neutral detergent to clean the boiler casing. Never use abrasive or powder detergents.

2.12 DECOMMISSIONING.

In the event of permanent shutdown of the boiler, contact professional staff for the procedures and ensure that the electrical, water and gas supply lines are shut off and disconnected.

3 BOILER START-UP (INITIAL CHECK).

To commission the boiler:

- ensure that the type of gas used corresponds to boiler settings;
- check connection to a 230V-50Hz power mains, correct L-N polarity and the earthing connection;
- make sure the central heating system is filled with water and that the boiler manometer indicates a pressure of 1÷1.2 bar.

- switch the boiler on and ensure correct ignition;
- check the proper calibration of the number of fan revolutions;
- check the CO₂ in the combustion products at maximum and minimum flow rate;
- check activation of the safety device in the event of no gas, as well as the relative activation time;
- check the intervention of the main switch located upstream of the boiler and in the boiler;
- check that the intake and/or exhaust terminals are not blocked;

- ensure activation of all adjustment devices;
- seal the gas flow rate regulation devices (if settings are modified);
- ensure production of domestic hot water (when the boiler is connected to an external storage tank unit);
- ensure sealing efficiency of water circuits;
- check ventilation and/or aeration of the installation room where provided.

Even if just one single safety check provides a negative result, do not commission the system.

3.1 BOILER HYDRAULIC DIAGRAM.

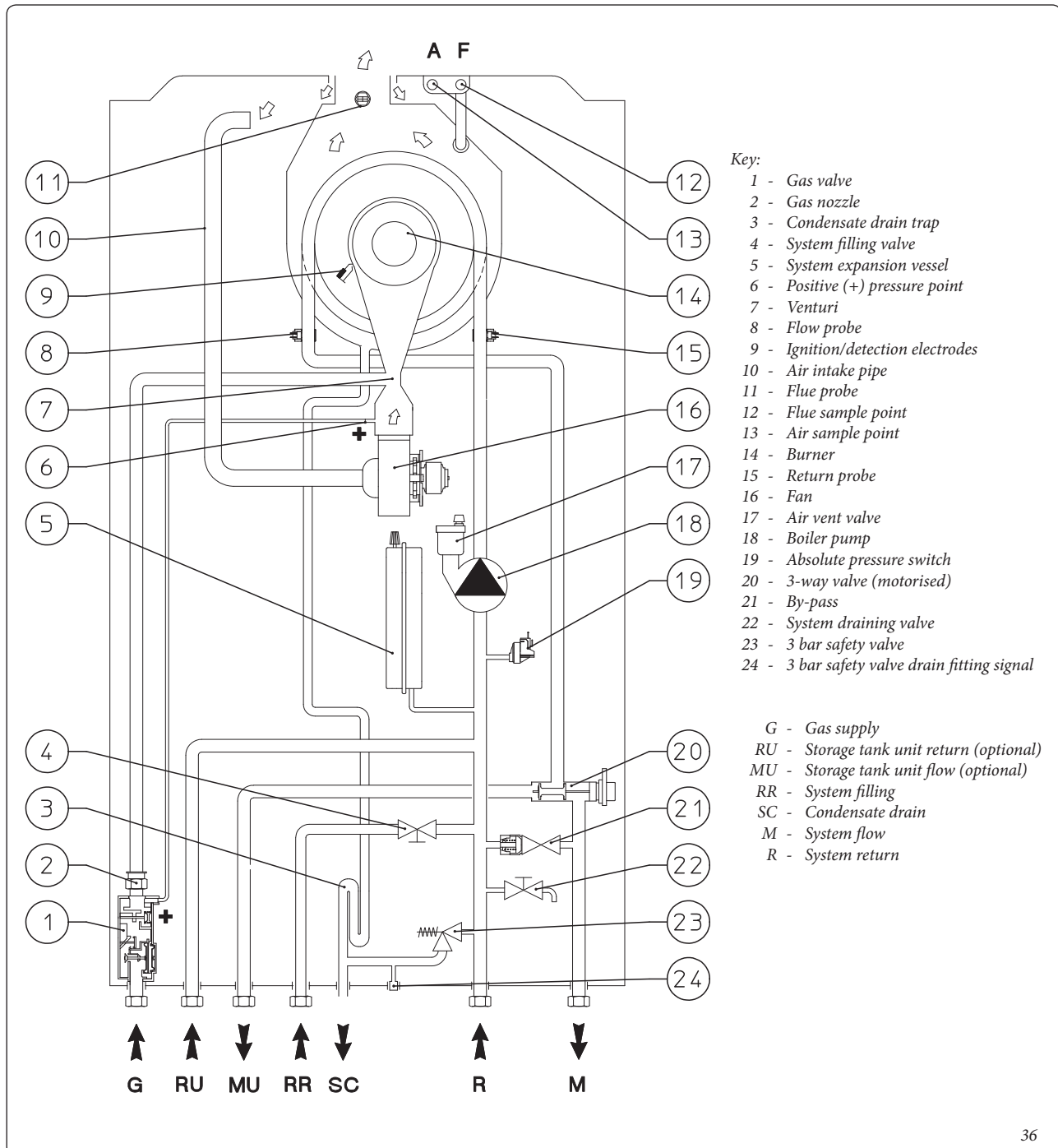

INSTALLER

USER

MAINTENANCE TECHNICIAN

3.2 WIRING DIAGRAM.

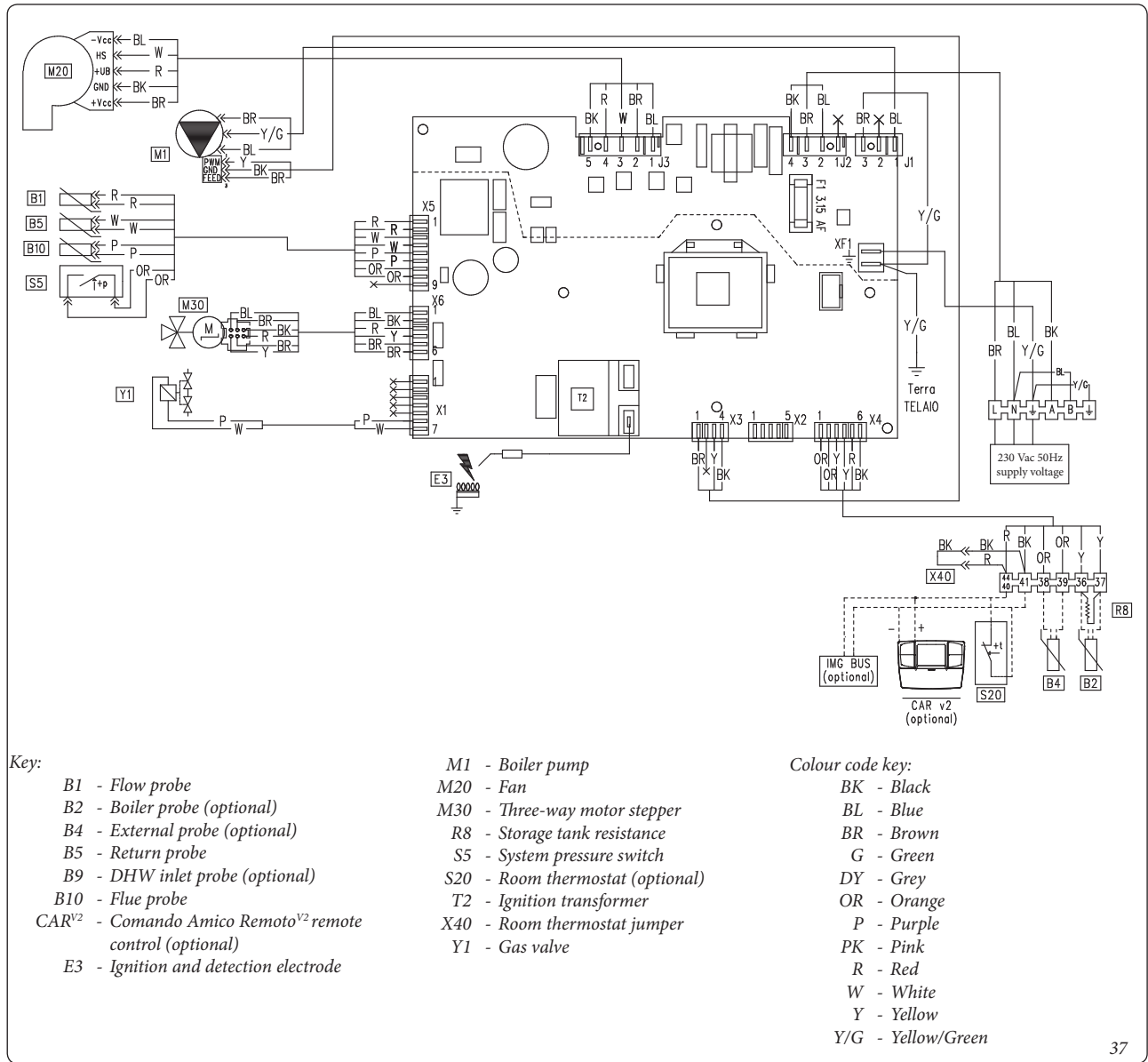

Comando Amico Remoto^{v2}: the boiler is prepared for the application of the Comando Amico Remoto remote control ^{v2} (CAR^{v2}), which must be connected to clamps 44/40 and 41 of the terminal board (located in the boiler control panel) respecting the polarity and eliminating jumper X40.

Room thermostat: the boiler is prepared for the application of the room thermostat (S20), which must be connected to clamps 44/40 - 41 of the terminal board (located in the boiler control panel) eliminating jumper X40.

Storage tank unit: the boiler is prepared for connection to a storage tank unit, which must be connected to terminals 36 and 37 of the terminal board (placed inside the connections compartment), eliminating resistance R8.

3.3 TROUBLESHOOTING

N.B.: maintenance interventions must be carried out by an authorised company (e.g. Authorized After-Sales Technical Assistance Service).

- Smell of gas. Caused by leakage from gas circuit pipelines. Check sealing efficiency of gas intake circuit.
- Repeated ignition blocks. It can be caused by no gas, check the presence of pressure in the network and that the gas adduction cock is open. Incorrect adjustment of the gas cock, check the correct calibration of the gas valve.
- Irregular combustion or noisiness. It may be caused by: a dirty burner, incorrect combustion parameters, intake-exhaust terminal not correctly installed. Clean the above components and ensure correct installation of the terminal, check correct setting of the gas valve (Off-Set setting) and correct percentage of CO₂ in flue gas.
- Frequent interventions of the safety thermostat function (delegated to flow probe and system return probe). It can depend on the lack of water in the boiler, little water circulation in the system or blocked pump. Check on the pressure gauge that the system pressure is within established limits. Check that the radiator valves are not closed and also the functionality of the pump.
- Siphon blocked. This may be caused by dirt or combustion products deposited inside. Check, by means of the condensate drain cap, that there are no residues of material blocking the flow of condensate.
- Heat exchanger blocked. This may be caused by the drain trap being blocked. Check, by means of the condensate drain cap, that there are no residues of material blocking the flow of condensate.
- Noise due to air in the system. Check opening of the special air vent valve cap (Part. 18 Fig. 34). Make sure the system pressure and expansion vessel pre-charge values are within the set limits; The factory-set pressure values of the expansion vessel must be 1.0 bar, the value of system pressure must be between 1 and 1.2 bar.

3.4 CONVERTING THE BOILER TO OTHER TYPES OF GAS.

If the boiler has to be converted to a different gas type to that specified on the data nameplate, request the relative conversion kit for quick and easy conversion.

The gas conversion operation must be carried out by an authorised company (e.g. Authorized After-Sales Technical Assistance Service).

To convert to another type of gas the following operations are required:

- remove the voltage from the appliance;
- replace the nozzle located on the gas valve and gas/air mixing sleeve (Part. 8 Fig. 34), taking care to disconnect the appliance during this operation;
- apply voltage to the appliance;
- calibrate the number of fan revolutions (Parag. 3.5);
- adjust the correct air/gas ratio (Parag. 3.6);
- seal the gas flow rate devices (if adjusted);
- after completing the conversion, apply the sticker, contained in the conversion kit, on the data plate in the area relating to the type of gas.

These adjustments must be made with reference to the type of gas used, following that given in the table (Par. 3.20).

3.5 CALIBRATION OF NUMBER OF FAN REVS.

Attention: verification and calibration is necessary, in the case of transformation to other types of gas, in the extraordinary maintenance phase with replacement of the PCB air/gas circuit components or in the case of installations with flue extraction systems, with horizontal concentric pipe measuring more than 1 metre.

The boiler heat output is correlated to the length of the air intake and flue exhaust pipes. This decreases with the increase of pipe length. The boiler leaves the factory adjusted for minimum pipe length (1m coaxial).

- activate flue test (Parag. 3.12);
- detect the flue signal ΔP (Ref. 12 Fig. 34);
- compare the signal ΔP and, if necessary, correct the S1 operating parameter with the following table:

Victrix Tera 24 Plus	
$\Delta P > 200$ Pa	
G20	S1 = 126 (6300 rpm)
G31	S1 = 121 (6050 rpm)

Attention: check the serial number on the boiler.

From number 7211394 use the data in the following table.

Victrix Tera 24 Plus	
$\Delta P > 200$ Pa	
G20	S1 = 126 (6300 rpm)
G31	S1 = 120 (6000 rpm)

3.6 ADJUSTMENT OF THE AIR-GAS RATIO.

Attention: the CO₂ verification operations must be carried out with the casing mounted, while the gas valve calibration operations must be carried out with the casing open and disconnecting the boiler from the power supply.

Calibration of the CO₂ at minimum output

Enter the chimney sweep mode without withdrawing DHW and set the output to minimum (0%). To have an exact value of CO₂ the technician must insert the sampling probe to the bottom of the sample point, then check that the CO₂ value is that specified in the table, otherwise adjust the screw (Part. 3 Fig. 38) (Off-Set adjuster). To increase the CO₂ value, turn the adjustment screw (3) in a clockwise direction and vice versa to decrease it.

Calibration of the CO₂ at maximum output

When you finish the minimum CO₂ adjustment, while maintaining the chimney sweep function active, set the output to maximum (99%). To have an exact value of CO₂ the technician must insert the sampling probe to the bottom of the sample point, then check that the CO₂ value is that specified in the table, otherwise adjust the screw (Part. 12 Fig. 38) (gas flow rate regulator). To increase the CO₂ value, turn the adjustment screw (12) in a clockwise direction and vice versa to decrease it.

At every adjustment variation on the screw 12 it is necessary to wait for the boiler to stabilise itself at the value set (about 30 sec.).

42 Gas Valve

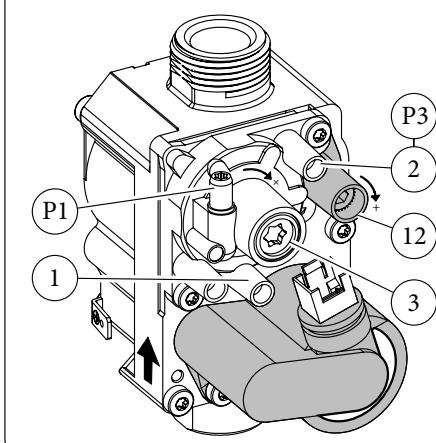

Key:

- 1 - Gas valve inlet pressure point
- 2 - Gas valve outlet pressure point
- 3 - Off/Set adjustment screw
- 12 - Outlet gas flow rate adjuster

38

3.7 CHECKS FOLLOWING CONVERSION TO ANOTHER TYPE OF GAS.

After making sure that conversion was carried out with a nozzle of suitable diameter for the type of gas used and the settings are made at the correct pressure, check that the burner flame is not too high or low and is stable (does not detach from burner);

N.B.: all boiler adjustment operations must be carried out by a qualified technician (e.g. Authorized After-Sales Assistance).

Victrix Tera 24 Plus		
	CO ₂ at maximum output	CO ₂ at minimum output
G 20	9.70 % + 0.50 / - 0,20	8.80 % + 0.20 / - 0.30
G 31	11.40 % ± 0,30	10.60 % ± 0.20

Attention: check the serial number on the boiler.

From number 7211394 use the data in the following table.

Victrix Tera 24 Plus		
	CO ₂ at maximum output	CO ₂ at minimum output
G 20	9.70 % + 0.30 / - 0,20	8.80 % + 0.20 / - 0.30
G 31	11.40 % ± 0,30	10.60 % ± 0.20

3.8 PROGRAMMING THE P.C.B.

The boiler is prepared for possible programming of several operation parameters. By modifying these parameters as described below, the boiler can be adapted according to specific needs.

To access the programming phase, press and hold the buttons "RESET" and "INFO" for more than 5 seconds, the display shows two dashes "--" flashing and you must enter the password to access the programming menus.

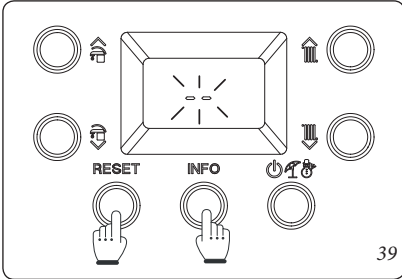

To enter the first digit use the buttons to adjust the DHW "P", to enter the second digit use the buttons to adjust the central heating temperature "19".

To confirm the password (69) and access the menu, press the operating mode button "MODE".

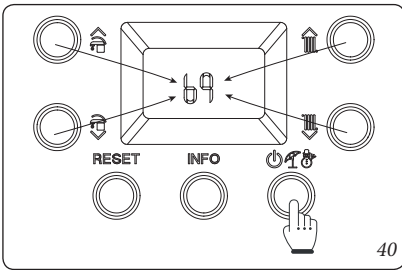

Once in the menu, you can cyclically scroll the four submenus (P, t, A, S) by pressing the DHW buttons "P", to access the menu press the button "MODE".

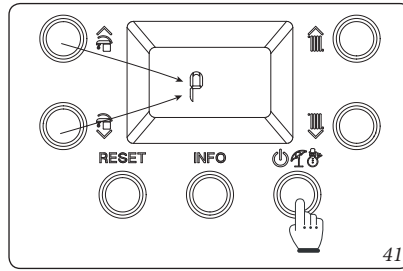

The first digit of the central indicator (19) shows the family of the parameter, while the second digit shows its number.

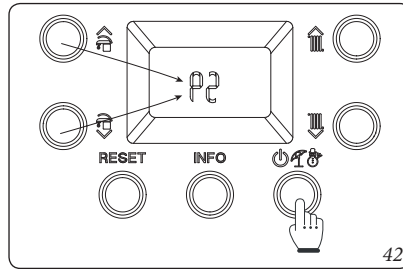

Pressing the mode of operation button "MODE" displays the value of the selected parameter and by pressing the buttons to adjust the central heating temperature "19" you can adjust its value.

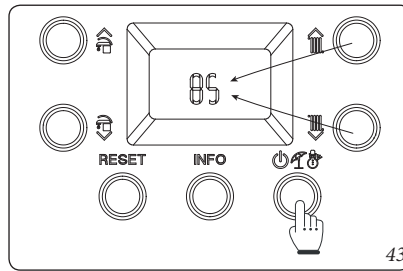

Press the mode of operation button "MODE" for more than 1 second to store the parameter value; confirmation is given by the word "OK" which appears for 2 seconds.

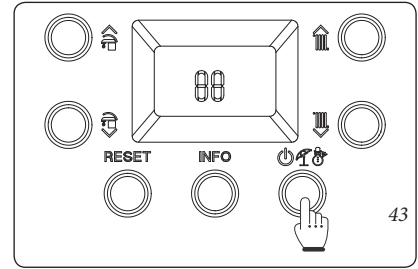

If you want to exit a parameter without changing its value, press the button "RESET".

Wait for 15 minutes or press the "RESET" button to exit programming mode.

INSTALLER

USER

MAINTENANCE TECHNICIAN

Programming phase sequence.

RESET + INFO > 5"	Menu "P" "t" "A" "S"	← RESET MODE	P0 ÷ P5 t0 ÷ t9 A0 ÷ A6 S0 ÷ S2	← RESET MODE	Parameter value	← RESET (Without mem- orising) MODE > 1" (Memorise)	"OK"
----------------------	----------------------------------	-----------------	--	-----------------	--------------------	---	------

45

Id Parameter	Parameter	Description	Range	Default	Customised value
P0	Max DHW output	Defines the maximum heat output percentage of the boiler during the D.H.W. phase compared to the maximum heat output available	0 - 100 %	100 %	
P1	Min CH output	Defines in percentage the minimum output in central heating mode	0 - P2	0 %	
P2	Max CH output	Defines the maximum heat output percentage of the boiler during the central heating mode compared to the maximum heat output available	0 - 100 %	G20 = 85 G31 = 82	
P3	-	Not available for this model	-	-	
P4	Pump functioning	The pump can function in two ways. 0 intermittent: in winter "mode" the circulator is managed by the room thermostat or by the remote control 1 continuous: in "winter" mode the circulator is always powered and is therefore always in operation	0 - 1	0	
P5	External probe correction	If the reading of the external probe is not correct it is possible to correct it in order to compensate any environmental factors.	-9 ÷ 9 K	0	
P6	-	Not available for this model	-	-	
P7	-	Not available for this model	-	-	

Id Parameter	Parameter	Description	Range	Default	Customised value
t0	Central heating set point minimum temperature	Defines the minimum flow temperature.	20 ÷ 50 °C	25	
t1	Central heating set point maximum temperature	Defines the maximum flow temperature.	(t0+5) ÷ 85 °C	85	
t2	-	Not available for this model	-	-	
t3	Domestic hot water priority timing	In winter mode the boiler, at the end of a domestic hot water request, is ready to switch to central heating mode if there is an active request. Timing sets a time period in which the boiler waits before changing the operating mode, in order to quickly and comfortably satisfy an additional request for domestic hot water.	0 - 100 seconds (step 10 sec)	2	
t4	Central heating ignitions timer	The boiler has electronic timing, which prevents the burner from igniting too often in central heating mode	0 - 600 seconds (step 10 sec)	18	
t5	Central heating ramp timer	In the heating stage, the boiler performs an ignition ramp in order to reach the maximum output set	0 - 840 seconds (step 10 sec)	18	
t6	CH ignition delay from TA and CR request	The boiler is set to switch-on immediately after a request. In the event of particular systems (e.g. area systems with motorised thermostatic valves etc.) it may be necessary to delay ignition	0 - 600 seconds (step 10 sec)	0	
t7	Display lighting	Establishes the display lighting mode. 0 : the display lights up during use and lowers after 15 seconds of inactivity. In the case of anomaly the display flashes. 1 : display lighting off. 2 : the display is always lit up.	0 - 2	0	
t8	Display	Establishes what the indicator displays 19 (Fig. 35). "Summer" mode: 0: the indicator is always off 1: pump active displays the flow temperature, pump off the indicator is off "Winter" mode: 0: always displays the value set on the CH selector 1: pump active displays the flow temperature, pump off always displays the value set on the CH selector	0 - 1	1	
t9	Flow off temperature increase	Increases the flow off temperature at ignition only in the first 60 seconds. After the flame is detected, the temperature is increased by t9	0 - 15	0	

Id Parameter	Parameter	Description	Range	Default	Customised value
A0	Hydraulic model	Defines the type of hydraulics in the boiler (0 = instant; 1 = storage tank)	0 ÷ 1	0	
A1	Maximum pump speed	Defines the maximum operating speed of the circulator (If A1 = A2 circulator operating at set speed)	A2 - 9	9	
A2	Minimum pump speed	Defines the minimum operating speed of the circulator	1 - A1	6	
A3	Pump operating mode	Sets the pump operating mode - DELTA T = 0: proportional head (see Parag. 1.28) - DELTA T = 5 ÷ 25 K: ΔT constant (see Parag. 1.28)	0 ÷ 25	15	
A4	Storage tank flow offset	Establishes the temperature to be added to the DHW set-point to calculate the flow set to heat the storage tank (only useful with a coupled storage tank and parameter A0=1).	5 ÷ 50 °C	25	
A5	Storage tank activation offset	Temperature value to be subtracted from the DHW set-point to calculate the boiler ignition to heat the storage tank (only useful with a coupled storage tank and parameter A0=1).	0 ÷ 15 °C	3	
A6	DHW thermostat	Establishes the switch-off method in DHW mode. 0 Fixed: the switch-off temperature is fixed at the maximum value regardless of the value set on the control panel. 1 Correlated: the boiler switches off according to the temperature set.	0 ÷ 1	0	

Id Parameter	Parameter	Description	Range	Default	Customised value
S0	DHW minimum no. of fan revs	Defines the operating speed of the fan at minimum DHW output	20 ÷ 60 (x 50 =RPM)	28 (G20) 27 (G31)	
S1	DHW maximum no. of fan revs	Defines the operating speed of the fan at maximum DHW output	S0 ÷ 140 (x 50 =RPM)	121 (G20) 115 (G31)	
S2	Ignition phase no. of fan revs	Defines the operating speed of the fan during the ignition phase	40 ÷ 80 (x 50 =RPM)	56 (G20) 56 (G31)	

Attention: check the serial number on the boiler.

From number 7211394 use the data in the following table.

Id Parameter	Parameter	Description	Range	Default	Customised value
S0	DHW minimum no. of fan revs	Defines the operating speed of the fan at minimum DHW output	20 ÷ 60 (x 50 =RPM)	27 (G20) 26 (G31)	
S1	DHW maximum no. of fan revs	Defines the operating speed of the fan at maximum DHW output	S0 ÷ 140 (x 50 =RPM)	121 (G20) 115 (G31)	
S2	Ignition phase no. of fan revs	Defines the operating speed of the fan during the ignition phase	40 ÷ 80 (x 50 =RPM)	56 (G20) 56 (G31)	

3.9 PASSWORD-PROTECTED SPECIAL FUNCTIONS.

Attention: the boiler is equipped with some special functions, access to which is granted if this is in stand-by (⏻).

IMPORTANT NOTE: if the boiler is connected to the CAR^{v2} the “stand-by” function can only be activated via the remote control panel.

Press and hold the “INFO” button for more than 5 seconds. The display will show two dashes “--” flashing. Now enter the password to access the programming menus.

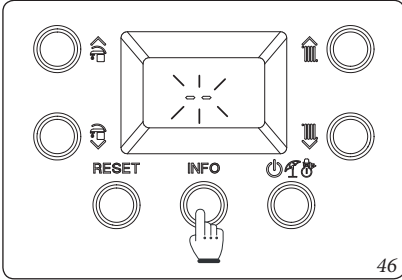

To enter the first digit use the buttons to adjust the DHW (⬆️⬆️), to enter the second digit use the buttons to adjust the central heating temperature (⬆️⬆️).

To confirm the password and access the menu, press the operating mode button (⏻).

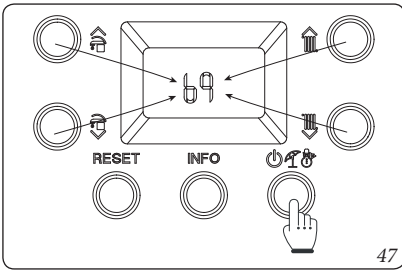

Once the menu has been accessed, it is possible to cyclically scroll the three available functions (dI, MA, FU) by pressing the DHW buttons (⬆️⬆️), to access the menu press the button (⏻) to exit wait 15 minutes or press the button “RESET”.

3.10 SCREED HEATER FUNCTION.

The boiler is equipped with a function to perform the thermal shock on new radiant panel systems, as required by the applicable standard.

Attention: contact the manufacturer of the radiant panels for the thermal shock characteristics and its correct execution.

N.B.: to be able to activate the function there must be no remote control connected, while in case of system divided into zones it must be properly connected, both hydraulically and electrically.

The function is activated from boiler in OFF by pressing and holding the buttons “Reset”, “Info” and “Stand-by” for more than 5 seconds.

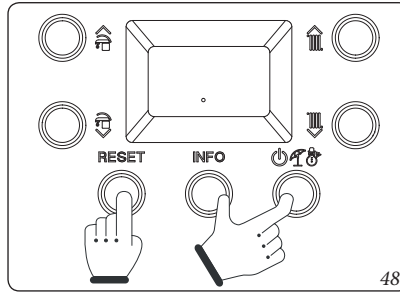

The function lasts in total 7 days, 3 days at the lower temperature set and 4 days at the higher temperature set (Fig. 49).

After activating the function, the lower set (range 20 ÷ 45 °C default = 25 °C) and the higher set (range 25 ÷ 55 °C default = 45 °C) appear in sequence.

The temperature is selected by means of the buttons “⬆️⬆️” and confirmed by pressing the button “⏻”.

The display now shows the countdown of days alternated with the current flow temperature, as well as the normal operating symbols of the boiler.

In case of failure or lack of supply voltage, the function is suspended and will resume when the normal operating conditions are reset from the point where it was interrupted.

When the time expires, the boiler automatically goes back to “Stand-by” mode, the function can also be stopped by pressing the button “⏻”.

3.11 AUTOMATIC VENT FUNCTION (dI).

In the case of new central heating systems and in particular mode for floor systems, it is very important that deaeration is performed correctly. The function consists of the cyclic activation of the pump (100 s ON, 20 s OFF) and the 3-way valve (120 s D.H.W., 120 s C.H.).

The function is activated by accessing the special “dI” function as described in Paragraph 3.9.

The function lasts for 16.5 hours and it can be stopped by simply pressing the button “RESET”.

Activation of the function is signalled by the countdown shown on the indicator (20).

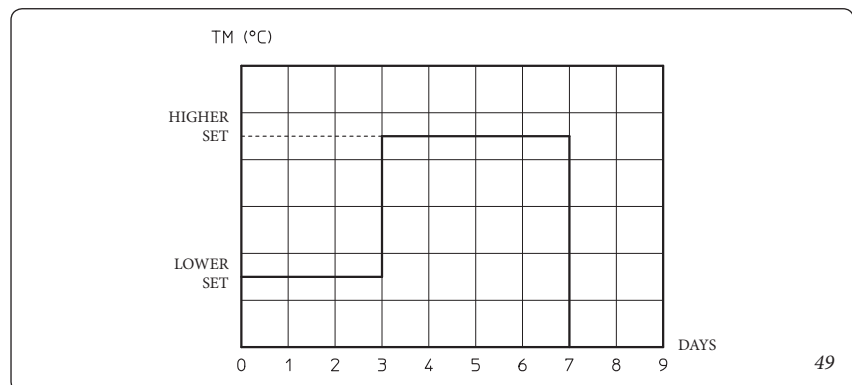

3.12 FLUE INSTALLATION (FU).

To activate the “Flue” function access the special functions as described in Paragraph 3.9 and select the “FU” function.

Attention: Before performing the test, ensure that the condensate drain trap has been filled correctly and check that there are no obstructions in the air intake circuit and flue exhaust.

Using this function activates the fan at a fixed speed (6000 rpm) for 15 minutes.

In this phase the symbols (⏻) and (⏻) are displayed flashing, while the symbol (⏻) is displayed permanently on, the function can be stopped by simply pressing the button “RESET”.

3.13 MAINTENANCE FUNCTION (MA).

Using this function you can activate some operating devices of the boiler without starting it, thus verifying the functionality.

The function is active for 15 minutes and it can be stopped by pressing the button “RESET”.

To activate the “Maintenance” function access the special functions as described in Paragraph 3.9 and select the “MA” function.

The following loads can be activated within this function:

- Fan (Fn): the fan is brought to ignition speed. Using the buttons “⬆️⬆️” you can increase or decrease the fan speed.
- Circulator (Pu): the circulator is brought to maximum speed, the relative speed is shown on the display, using the buttons “⬆️⬆️” you can increase or decrease the circulator speed.
- Three-way (3d): the symbol is shown on the display according to the position of the valve, DHW (⏻) or central heating (⏻), using the buttons “⬆️⬆️” you can change the valve position, taking care to wait for the completion of passage between statuses.
- Configurable relay (rl): if the configurable relay is present on the boiler P.C.B., it is activated.

3.14 "CHIMNEY SWEEP FUNCTION".

When activated, this function forces the boiler to variable output for 15 minutes.

In this state all adjustments are excluded and only the safety thermostat and the limit thermostat remain active. To activate the chimney sweep function, press the "RESET" button until activation of the function in the absence of DHW requests.

Its activation on the boiler display is confirmed by the indicators flashing at the same time (17 and 18 Fig. 35).

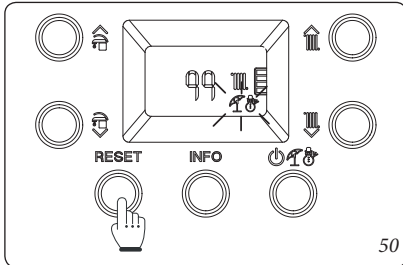

This function allows the technician to check the combustion parameters.

Once the function is activated, it is possible to select whether to make the check in CH status or DHW status by opening any hot water cock.

Using the buttons "⏠" and "⏚" you can select between three predefined power levels:

- "0%"
- Max CH output (P2)
- Max DHW output (P0).

While by using the buttons "⏠" and "⏚", you can select the power from 0% to max DHW output (P0), with intervals of 1%.

The central heating or DHW operating mode is displayed by the relative symbols "⏠" or "⏚". After the checks, deactivate the function switching the boiler off and then on again.

3.15 PUMP ANTI-BLOCK FUNCTION.

The boiler has a function that starts the pump at least once every 24 hours for the duration of 30 seconds in order to reduce the risk of the pump becoming blocked due to prolonged inactivity.

3.16 THREE-WAY ANTI-BLOCK SYSTEM

Both in "domestic hot water" and in "domestic hot water-central heating" phase the boiler is equipped with a function that starts the three-way motorised group 24 hours after it was last in operation, running it for a full cycle so as to reduce the risk of the three-way group becoming blocked due to prolonged inactivity.

3.17 RADIATORS ANTIFREEZE FUNCTION.

If the system return water is below 4°C, the boiler starts up until reaching 42°C.

3.18 YEARLY APPLIANCE CHECK AND MAINTENANCE.

The following checks and maintenance should be performed at least once a year.

- Clean the flue side of the heat exchanger.
- Clean the main burner.
- Check the correct positioning, integrity and cleanliness of the detection and ignition electrode; remove any oxide present.
- If deposits are detected in the combustion chamber one must remove them and clean the exchanger coils using nylon or sorghum brushes; it is forbidden to use brushes made of metal or other materials that may damage the combustion chamber itself.
- Check the integrity of the insulating panels inside the combustion chamber and if damaged replace them.
- Visually check for water leaks or oxidation from/on connections and traces of condensate residues inside the sealed chamber.
- Check the contents of the condensate drain trap.
- Check that there are no material residues in the condensate drain siphon clogging the condensate passage; also check that the entire condensate drainage circuit is clear and efficient.

In the event of obstructions (dirt, sediment, etc.) with consequent leakage of condensate in the combustion chamber, one must replace the insulating panels.

- Check that the burner and gas manifold seal gaskets are intact and perfectly efficient, otherwise replace them. In any case the gaskets must be replaced at least every two years, regardless of their state of wear.
- Check that the burner is intact, that it has no deformations or cuts and that it is properly fixed to the combustion chamber lid; otherwise it must be replaced.
- Visually check that the water safety drain valve is not blocked.
- Check that, after discharging the system pressure and bringing it to zero (read on boiler pressure gauge), the expansion vessel pressure is at 1.0 bar.
- Check that the system static pressure (with system cold and after refilling the system by means of the filling valve) is between 1 and 1.2 bar.
- Check visually that the safety and control devices have not been tampered with and/or shorted, in particular:
 - check the integrity of the storage tank's Magnesium Anode (when the boiler is connected to an external storage tank unit).
- Check the condition and integrity of the electrical system and in particular:
 - electrical power cables must be inside the fairleads;
 - there must be no traces of blackening or burning.
- Check correct lighting and operation.
- Ensure correct calibration of the burner in domestic water (when the boiler is connected to an external storage tank unit) and heating phases.

- Check correct operation of control and adjustment devices and in particular:
 - system regulation probes intervention;
 - domestic hot water control thermostat intervention (when the boiler is connected to an external storage tank unit).
- Check sealing efficiency of gas circuit and the internal system.
- Check the intervention of the device against no gas ionisation flame control. Intervention time must be less than 10 seconds.

N.B.: in addition to yearly maintenance, one must also check the thermal system, with frequency and procedures that comply with the indications of the technical regulations in force.

3.19 CASING REMOVAL.

To facilitate boiler maintenance the casing can be completely removed as follows:

• **Lower grid (Fig. 51).**

- 1) Loosen the two screws (a).
- 2) Press the hooks inwards, which block the lower grid (b).
- 3) remove the grid (b).

• **Front panel (Fig. 52).**

- 4) Remove the cover caps (c) and loosen screws (d).
- 5) Pull the front panel (e) towards you and release it from its lower seat.

• **Front (Fig. 53).**

- 6) Loosen the two screws (g).
- 7) Pull the front (f) slightly towards you.
- 8) Release front (f) from pins (h) pulling it towards you while pushing it upwards at the same time.

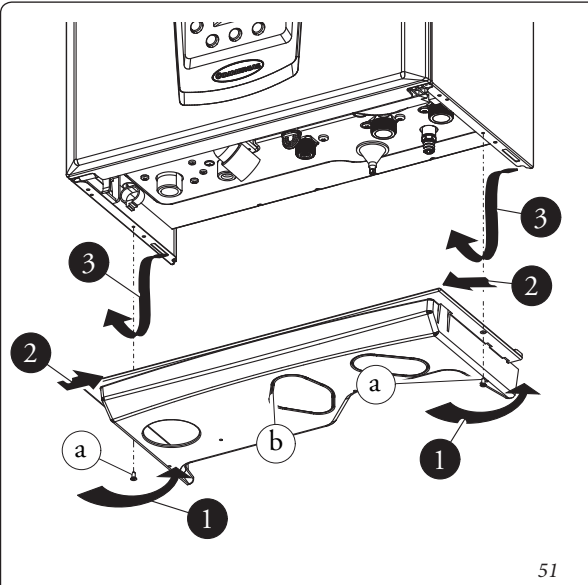

51

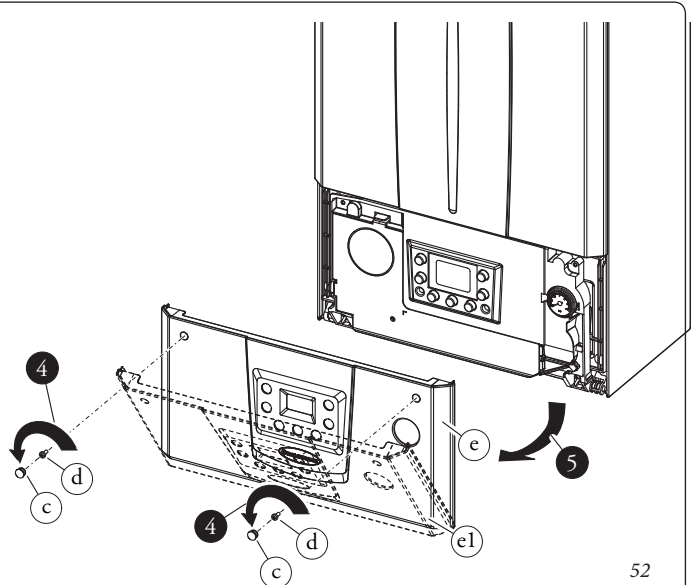

52

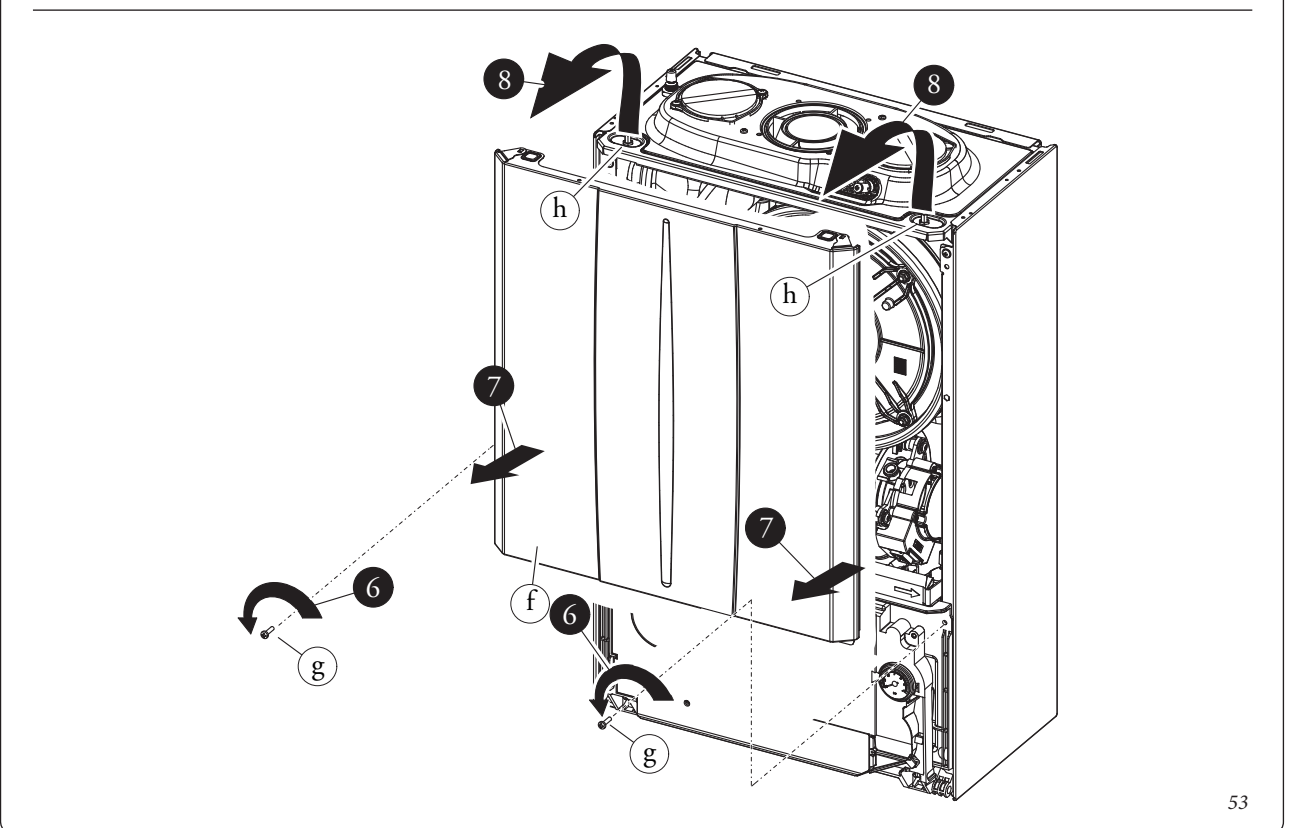

53

• Control panel (Fig. 54).

- 9) Press the hooks on the side of the control panel (i).
- 10) Tilt the control panel (i) towards you.

• Sides (Fig. 55).

- 11) Loosen screws (k) of side fastening (j).
- 12) Remove the sides by extracting them from their rear seat (Ref. X).

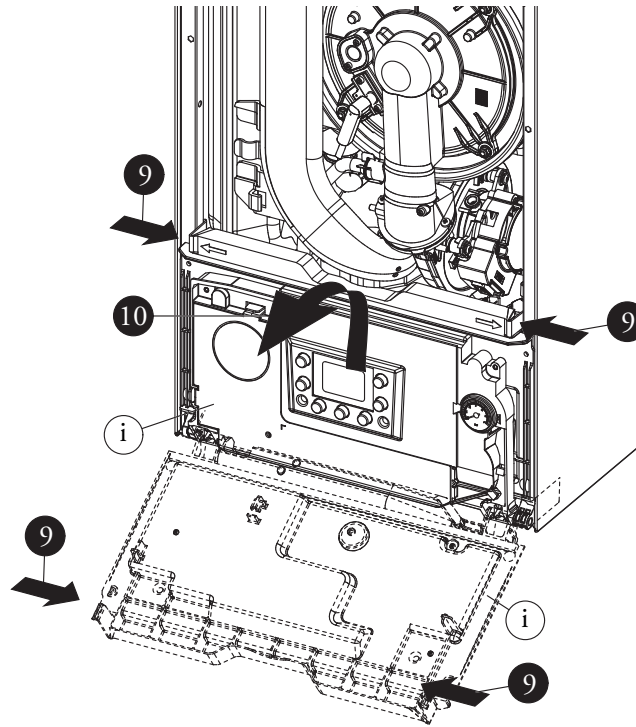

54

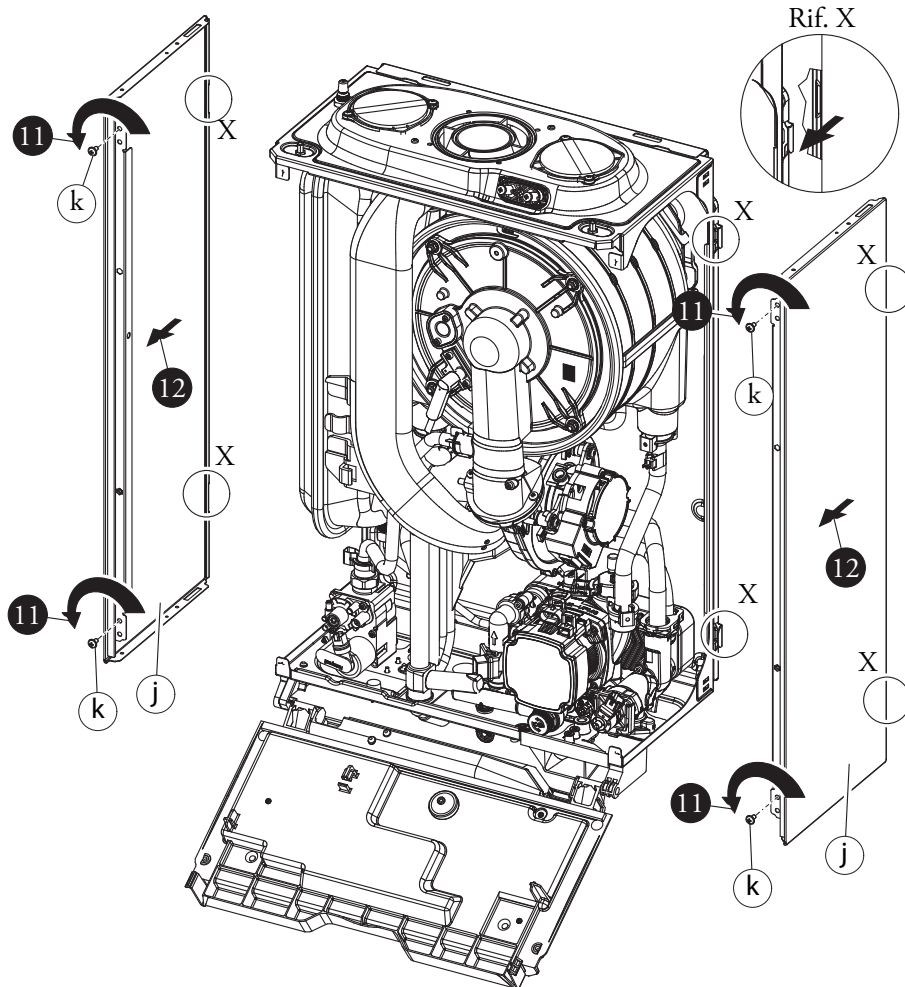

55

INSTALLER

USER

MAINTENANCE TECHNICIAN

3.20 VARIABLE HEAT OUTPUT.

N.B.: the power data in the table has been obtained with intake-exhaust pipe measuring 0.5 m

in length. Gas flow rates refer to net heating value below a temperature of 15°C and at a pressure of 1013 mbar.

				METHANE (G20)		PROPANE (G31)	
HEAT POWER	HEAT POWER		MODULATION	GAS FLOW RATE BURNER	MODULATION	GAS FLOW RATE BURNER	
(kW)	(kcal/h)		(%)	(m ³ /h)	(%)	(kg/h)	
28.3	24295	D.H.W.	99	3.06	100	2.25	
27.5	23650		97	2.98	97	2.19	
26.5	22790		94	2.87	92	2.11	
25.5	21930		90	2.76	88	2.03	
24.1	20717		85	2.61	82	1.91	
23.5	20210	CEN. HEAT. + D.H.W.	83	2.54	80	1.87	
22.7	19542		80	2.46	76	1.81	
21.5	18490		76	2.33	71	1.71	
20.5	17630		72	2.22	67	1.63	
19.5	16770		68	2.11	63	1.55	
18.5	15910		65	2.01	59	1.47	
17.5	15050		61	1.90	55	1.39	
16.5	14190		57	1.79	51	1.31	
15.5	13330		53	1.68	47	1.24	
14.5	12470		48	1.58	42	1.16	
13.5	11610		44	1.47	38	1.08	
12.5	10750		40	1.36	34	1.00	
11.5	9890		35	1.26	30	0.92	
10.5	9030		31	1.15	26	0.84	
9.5	8170		26	1.04	22	0.76	
8.5	7310		22	0.93	18	0.68	
7.5	6450		17	0.82	14	0.61	
6.5	5590		12	0.72	10	0.53	
5.5	4730		7	0.61	6	0.45	
4.5	3870		2	0.50	2	0.37	
4.3	3689	1	0.48	1	0.35		

3.21 COMBUSTION PARAMETERS.

		G20	G31
Supply pressure	mbar (mm H ₂ O)	20 (204)	37 (377)
Gas nozzle diameter	mm	5.00	3.80
Flue flow rate at nominal heat output	kg/h	44	43
Flue flow rate at min heat output	kg/h	8	7
CO ₂ at Nom./Min. Q.	%	9.70 / 8.80	11.40 / 10.60
CO with 0% O ₂ at Nom./Min. Q.	ppm	300 / 5	400 / 5
NO _x with 0% O ₂ at Nom./Min. Q.	mg/kWh	57 / 27	81 / 36
Flue temperature at nominal output	°C	70	70
Flue temperature at minimum output	°C	64	63

Combustion parameters: measuring conditions of useful efficiency (flow temperature/return temperature= 80 / 60 °C), ambient temperature reference = 15°C.

INSTALLER

USER

MAINTENANCE TECHNICIAN

3.22 TECHNICAL DATA.

Domestic hot water nominal heat input	kW (kcal/h)	28.8 (24773)
Central heating nominal heat input	kW (kcal/h)	24.6 (21194)
Minimum heat input	kW (kcal/h)	4.5 (3862)
Domestic hot water nominal heat output (useful)	kW (kcal/h)	28.3 (24295)
Central heating nominal heat output (useful)	kW (kcal/h)	24.1 (20717)
Minimum heat output (useful)	kW (kcal/h)	4.3 (3689)
*Effective thermal efficiency 80/60 Nom./Min.	%	97.8 / 95.5
*Effective thermal efficiency 50/30 Nom./Min.	%	106.1 / 106.1
*Effective thermal efficiency 40/30 Nom./Min.	%	108.2 / 108.3
Casing losses with burner On/Off (80-60°C)	%	0.34 / 0.20
Heat loss at flue with burner On/Off (80-60°C)	%	0.02 / 1.70
Central heating circuit max. operating pressure	bar	3
Maximum central heating temperature	°C	90
Adjustable central heating temperature (max operating field)	°C	20 - 85
System expansion vessel total volume	l	5.8
Expansion vessel factory-set pressure	bar	1.0
Appliance water content	l	1.8
Head available with 1000 l/h flow rate	kPa (m H ₂ O)	9.19 (0.9)
Hot water production useful heat output	kW (kcal/h)	28.3 (24295)
Domestic hot water adjustable temperature	°C	30 - 60
Weight of full boiler	kg	33.8
Weight of empty boiler	kg	32.0
Electrical connection	V/Hz	230 / 50
Nominal power absorption	A	0.60
Installed electric power	W	80
Pump absorbed power	W	41
EEl value	-	≤ 0.20 - Part. 3
Equipment electrical system protection	-	IPX5D
Max temperature of combustion products	°C	75
Max. flue overheating temperature	°C	120
NO _x class	-	6
Weighted NO _x	mg/kWh	35.0
Weighted CO	mg/kWh	20.0
Type of appliance	C13 / C13x / C33 / C33x / C43 / C43x / C53 / C63 / C83 / C83x / C93 / C93x / B23 / B33 / B53	
Category	II 2H3P	

- The data relating to domestic hot water performance refer to a dynamic inlet pressure of 2 bar and an inlet temperature of 15°C; the values are measured immediately at the boiler outlet, considering that to obtain the data declared, mixing with cold water is required.

- * Efficiencies refer to the lower heating value.

- The weighted NO_x value refer to the net calorific value.

Attention: check the serial number on the boiler.
From number 7211394 use the data in the following tables.

3.23 VARIABLE HEAT OUTPUT.

N.B.: the power data in the table has been obtained with intake-exhaust pipe measuring 0.5 m

in length. Gas flow rates refer to net heating value below a temperature of 15°C and at a pressure of 1013 mbar.

				METHANE (G20)		PROPANE (G31)	
HEAT POWER	HEAT POWER		MODULATION	GAS FLOW RATE BURNER	MODULATION	GAS FLOW RATE BURNER	
(kW)	(kcal/h)		(%)	(m ³ /h)	(%)	(kg/h)	
28,3	24295	D.H.W.	99	3,06	99	2,25	
27,5	23650		97	2,98	97	2,19	
26,5	22790		93	2,87	93	2,11	
25,5	21930		89	2,76	88	2,03	
24,1	20717		85	2,61	82	1,91	
23,5	20210	CEN. HEAT. + D.H.W.	81	2,54	80	1,87	
22,5	19350		78	2,44	76	1,79	
21,5	18490		74	2,33	72	1,71	
20,5	17630		70	2,22	68	1,63	
19,5	16770		66	2,11	64	1,55	
18,5	15910		62	2,01	60	1,47	
17,5	15050		58	1,90	56	1,39	
16,5	14190		54	1,79	52	1,31	
15,5	13330		50	1,68	48	1,24	
14,5	12470		45	1,58	43	1,16	
13,5	11610		41	1,47	39	1,08	
12,5	10750		37	1,36	35	1,00	
11,5	9890		33	1,26	31	0,92	
10,5	9030		29	1,15	27	0,84	
9,5	8170		24	1,04	23	0,76	
8,5	7310		20	0,93	19	0,68	
7,5	6450		16	0,82	15	0,61	
6,5	5590		11	0,72	11	0,53	
5,5	4730		7	0,61	6	0,45	
4,5	3870		2	0,50	2	0,37	
4,3	3689		1	0,48	1	0,35	

INSTALLER

USER

MAINTENANCE TECHNICIAN

3.24 COMBUSTION PARAMETERS.

		G20	G31
Supply pressure	mbar (mm H ₂ O)	20 (204)	37 (377)
Gas nozzle diameter	mm	5.00	3.80
Flue flow rate at nominal heat output	kg/h	44	43
Flue flow rate at min heat output	kg/h	8	7
CO ₂ at Nom./Min. Q.	%	9.70 / 8.80	11.40 / 10.60
CO with 0% O ₂ at Nom./Min. Q.	ppm	360 / 7	560 / 9
NO _x with 0% O ₂ at Nom./Min. Q.	mg/kWh	57 / 27	81 / 55
Flue temperature at nominal output	°C	70	70
Flue temperature at minimum output	°C	64	63

Combustion parameters: measuring conditions of useful efficiency (flow temperature/return temperature= 80 / 60 °C), ambient temperature reference = 15°C.

3.25 TECHNICAL DATA.

Domestic hot water nominal heat input	kW (kcal/h)	28.8 (24773)
Central heating nominal heat input	kW (kcal/h)	24.6 (21194)
Minimum heat input	kW (kcal/h)	4.5 (3862)
Domestic hot water nominal heat output (useful)	kW (kcal/h)	28.3 (24295)
Central heating nominal heat output (useful)	kW (kcal/h)	24.1 (20717)
Minimum heat output (useful)	kW (kcal/h)	4.3 (3689)
*Effective thermal efficiency 80/60 Nom./Min.	%	97.8 / 95.5
*Effective thermal efficiency 50/30 Nom./Min.	%	106.1 / 106.1
*Effective thermal efficiency 40/30 Nom./Min.	%	108.2 / 108.3
Casing losses with burner On/Off (80-60°C)	%	0.34 / 0.20
Heat loss at flue with burner On/Off (80-60°C)	%	0.02 / 1.70
Central heating circuit max. operating pressure	bar	3
Maximum central heating temperature	°C	90
Adjustable central heating temperature (max operating field)	°C	20 - 85
System expansion vessel total volume	l	5.8
Expansion vessel factory-set pressure	bar	1.0
Appliance water content	l	1.8
Head available with 1000 l/h flow rate	kPa (m H ₂ O)	9.19 (0.9)
Hot water production useful heat output	kW (kcal/h)	28.3 (24295)
Domestic hot water adjustable temperature	°C	30 - 60
Weight of full boiler	kg	33.8
Weight of empty boiler	kg	32.0
Electrical connection	V/Hz	230 / 50
Nominal power absorption	A	0.60
Installed electric power	W	80
Pump absorbed power	W	41
EEl value	-	≤ 0.20 - Part. 3
Equipment electrical system protection	-	IPX5D
Max temperature of combustion products	°C	75
Max. flue overheating temperature	°C	120
NO _x class	-	6
Weighted NO _x	mg/kWh	35.0
Weighted CO	mg/kWh	20.0
Type of appliance	C13 / C13x / C33 / C33x / C43 / C43x / C53 / C63 / C83 / C83x / C93 / C93x / B23 / B33 / B53	
Category	I 3P	

- The data relating to domestic hot water performance refer to a dynamic inlet pressure of 2 bar and an inlet temperature of 15°C; the values are measured immediately at the boiler outlet, considering that to obtain the data declared, mixing with cold water is required.

- * Efficiencies refer to the lower heating value.

- The weighted NO_x value refer to the net calorific value.

INSTALLER

USER

MAINTENANCE TECHNICIAN

3.26 KEY FOR DATA NAMEPLATE.

Md		Cod. Md	
Sr N°	CHK	Cod. PIN	
Type			
Q _{nw} /Q _n min.	Q _{nw} /Q _n max.	P _n min.	P _n max.
PMS	PMW	D	TM
NO _x Class			
			CONDENSING

N.B.: the technical data is provided on the data plate on the boiler

	IE
Md	Model
Code Md	Model code
Sr N°	Serial Number
CHK	Check
Code PIN	PIN code
Type	Type of installation (ref. CEN TR 1749)
Q _{nw} min.	Minimum DHW heat input
Q _n min.	CH minimum heat input
Q _{nw} max.	DHW maximum heat input
Q _n max.	CH maximum heat input
P _n min.	Minimum heat output
P _n max.	Maximum heat output
PMS	Maximum system pressure
PMW	Maximum domestic hot water pressure
D	Specific flow rate
TM	Maximum operating temperature
NO _x Class	NO _x Class
CONDENSING	Condensing boiler

3.27 TECHNICAL PARAMETERS FOR COMBINATION BOILERS (IN COMPLIANCE WITH REGULATION 813/2013).

Efficiencies in the following tables refer to the gross calorific value.

Model/s:				Victrix Tera 24 Plus					
Condensing Boilers:				YES					
Low temperature boiler:				NO					
Boiler type B1:				NO					
Co-generation appliance for central heating:				NO		Fitted with supplementary heating system:		NO	
Mixed heating appliance:				NO					
Element	Symbol	Value	Unit	Element	Symbol	Value	Unit		
Nominal heat output	P_n	24	kW	Seasonal energy efficiency of central heating	η_s	93	%		
For central heating only and combination boilers: useful heat output				For central heating only and combination boilers: useful efficiency					
At nominal heat output in high temperature mode (*)	P_4	24.0	kW	At nominal heat output in high temperature mode (*)	η_4	88.1	%		
At 30% of nominal heat output in a low temperature mode (**)	P_1	8.0	kW	At 30% of nominal heat output in a low temperature mode (**)	η_1	97.6	%		
Auxiliary electricity consumption				Other items					
At full load	el_{max}	0.010	kW	Heat loss in standby	P_{stby}	0.057	kW		
At partial load	el_{min}	0.005	kW	Ignition burner energy consumption	P_{ign}	0.000	kW		
In standby mode	P_{SB}	0.002	kW	Emissions of nitrogen oxides	NO_x	35	mg / kWh		
For mixed central heating appliances									
Stated load profile			-		Domestic hot water production efficiency		η_{WH}	0	%
Daily electrical power consumption		Q_{elec}	0.0	kWh	Daily gas consumption		Q_{fuel}	0	kWh
Contact information		IMMERGAS S.p.A. VIA CISA LIGURE, 95 - 42041 BRESCELLO (RE) ITALY							
(*) High temperature mode means 60°C on return and 80°C on flow.									
(**) Low temperature mode for condensation Boilers means 30°C , for low temperature boilers 37°C and for other appliances 50°C of return temperature.									

3.28 PRODUCT FICHE (IN COMPLIANCE WITH REGULATION 811/2013).

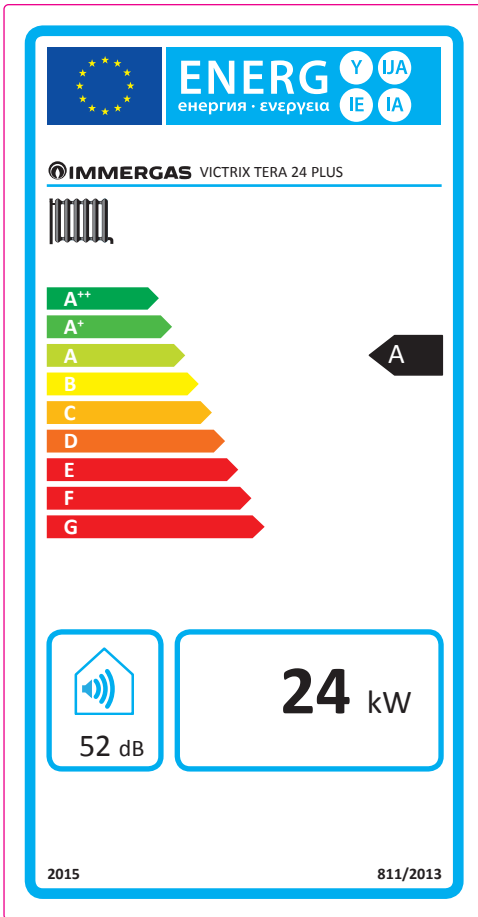

Parameter	value
Annual energy consumption for the heating function (Q_{HE})	1.5 GJ
Annual electricity consumption for the domestic hot water function (AEC)	-
Annual fuel consumption for the domestic hot water function (AFC)	-
Seasonal space heating energy efficiency (η_s)	93 %
Water heating energy efficiency (η_{wh})	-

For proper installation of the appliance refer to chapter 1 of this booklet (for the installer) and current installation regulations. For proper maintenance refer to chapter 3 of this booklet (for the maintenance technician) and adhere to the frequencies and methods set out herein.

3.29 PARAMETERS FOR FILLING THE PACKAGE FICHE.

In case you should wish to install an assembly, starting from the Victrix Tera 24 Plus boiler, use the package fiches in Fig. 58 and 61.

To complete it properly, fill the relevant spaces (as shown in the package fiche facsimile Fig. 56 and 59) with the values shown in tables Fig. 57 and 60.

The remaining values must be obtained from the technical data sheets of the products used to make up the assembly (e.g. solar devices, integration heat pumps, temperature controllers). Use board Fig. 58 for “assemblies” related to the central heating mode (e.g.: boiler + temperature controller).

Use board Fig. 61 for “assemblies” related to the domestic hot water function (e.g.: boiler + solar thermal system).

Facsimile for filling in the package fiche for preferential boiler space heaters.

Seasonal central heating energy efficiency of the boiler ① %

Temperature control ② %
 From temperature control board

Class I = 1 %, Class II = 2 %,
 Class III = 1.5 %, Class IV = 2 %,
 Class V = 3 %, Class VI = 4 %,
 Class VII = 3.5 %, Class VIII = 5 %

Supplementary boiler ③ %
 From boiler board

Seasonal central heating energy efficiency (in %)

$$(\text{ } - \text{'I'}) \times 0.1 = \pm \text{ } \%$$

Solar contribution

From the board of the solar device

Dimensions of the manifold (in m²)

Volume of the tank (in m³)

Efficiency of the manifold (in %)

Classification of the tank
A* = 0.95, A = 0.91,
B = 0.86, C = 0.83,
D-G = 0.81

$$(\text{'III'} \times \text{ } + \text{'IV'} \times \text{ }) \times (0.9 \times (\text{ } / 100)) \times \text{ } = + \text{ } \%$$

Supplementary heat pump ⑤ %
 From the heat pump board

Seasonal central heating energy efficiency (in %)

$$(\text{ } - \text{'I'}) \times \text{'II'} = + \text{ } \%$$

Solar contribution and supplementary heat pump

Select the lowest value ⑥ %

$$0.5 \times \text{ } \text{ O } 0.5 \times \text{ } = - \text{ } \%$$

Seasonal central heating energy efficiency of the set ⑦ %

Seasonal central heating energy efficiency class of the set

<input type="checkbox"/>	<input type="checkbox"/>	<input type="checkbox"/>	<input type="checkbox"/>	<input type="checkbox"/>	<input type="checkbox"/>	<input type="checkbox"/>	<input type="checkbox"/>	<input type="checkbox"/>	<input type="checkbox"/>
G	F	E	D	C	B	A	A ⁺	A ⁺⁺	A ⁺⁺⁺
< 30 %	≥ 30 %	≥ 34 %	≥ 36 %	≥ 75 %	≥ 82 %	≥ 90 %	≥ 98 %	≥ 125 %	≥ 150 %

Boiler and supplementary heat pump installed with low temperature heat emitters at 35 °C?

From the board of the heat pump ⑦ + (50 x 'II') = %

The energy efficiency of the set of products indicated in this fiche may not reflect the actual energy efficiency after installation since such efficiency is affected by additional factors, such as the heat loss in the distribution system and the size of the products compared to the size and features of the building.

Parameters for filling in the package fiche.

Parameter	Victrix Tera 24 Plus
'I'	93
'II'	*
'III'	1.11
'IV'	0.44

* to be established by means of table 5 of Regulation 811/2013 in case of "assembly" including a heat pump to integrate the boiler. In this case the boiler must be considered as the main appliance of the assembly.

57

Room heating system package fiche.

Seasonal central heating energy efficiency of the boiler 1 %

Temperature control 2 %
 From temperature control board

Class I = 1 %, Class II = 2 %,
 Class III = 1.5 %, Class IV = 2 %,
 Class V = 3 %, Class VI = 4 %,
 Class VII = 3.5 %, Class VIII = 5 %

Supplementary boiler 3 %
 From boiler board

Seasonal central heating energy efficiency (in %)

$$(\text{ } - \text{ }) \times 0.1 = \pm \text{ } \%$$

Solar contribution 4 %
 From the board of the solar device

Dimensions of the manifold (in m²)

Volume of the tank (in m³)

Efficiency of the manifold (in %)

Classification of the tank
A* = 0.95, A = 0.91,
B = 0.86, C = 0.83,
D-G = 0.81

$$(\text{ } \times \text{ } + \text{ } \times \text{ }) \times (0.9 \times (\text{ } / 100) \times \text{ } = + \text{ } \%$$

Supplementary heat pump 5 %
 From the heat pump board

Seasonal central heating energy efficiency (in %)

$$(\text{ } - \text{ }) \times \text{ } = + \text{ } \%$$

Solar contribution and supplementary heat pump 6 %
 Select the lowest value

$$0.5 \times \text{ } \text{ O } 0.5 \times \text{ } = - \text{ } \%$$

Seasonal central heating energy efficiency of the set 7 %

Seasonal central heating energy efficiency class of the set

G	F	E	D	C	B	A	A ⁺	A ⁺⁺	A ⁺⁺⁺
< 30 %	≥ 30 %	≥ 34 %	≥ 36 %	≥ 75 %	≥ 82 %	≥ 90 %	≥ 98 %	≥ 125 %	≥ 150 %

Boiler and supplementary heat pump installed with low temperature heat emitters at 35 °C? 7 %
 From the board of the heat pump.

$$\text{ } + (50 \times \text{ }) = \text{ } \%$$

The energy efficiency of the set of products indicated in this fiche may not reflect the actual energy efficiency after installation since such efficiency is affected by additional factors, such as the heat loss in the distribution system and the size of the products compared to the size and features of the building.

58



Facsimile for filling in domestic hot water production system package fiche.

Water heating energy efficiency of combination boiler

¹
 %

Stated load profile:

Solar contribution

From the board of the solar device

Auxiliary electricity

(1,1 x 'I' - 10 %) x 'II' - - 'I' = + %

Water heating energy efficiency of the set in average climate conditions

³
 %

Water heating energy efficiency class of the set in average climate conditions

	<input type="checkbox"/>	<input type="checkbox"/>	<input type="checkbox"/>	<input type="checkbox"/>	<input type="checkbox"/>	<input type="checkbox"/>	<input type="checkbox"/>	<input type="checkbox"/>	<input type="checkbox"/>	<input type="checkbox"/>
	G	F	E	D	C	B	A	A ⁺	A ⁺⁺	A ⁺⁺⁺
<input type="checkbox"/> M	< 27 %	≥ 27 %	≥ 30 %	≥ 33 %	≥ 36 %	≥ 39 %	≥ 65 %	≥ 100 %	≥ 130 %	≥ 163 %
<input type="checkbox"/> L	< 27 %	≥ 27 %	≥ 30 %	≥ 34 %	≥ 37 %	≥ 50 %	≥ 75 %	≥ 115 %	≥ 150 %	≥ 188 %
<input type="checkbox"/> XL	< 27 %	≥ 27 %	≥ 30 %	≥ 35 %	≥ 38 %	≥ 55 %	≥ 80 %	≥ 123 %	≥ 160 %	≥ 200 %
<input type="checkbox"/> XXL	< 28 %	≥ 28 %	≥ 32 %	≥ 36 %	≥ 40 %	≥ 60 %	≥ 85 %	≥ 131 %	≥ 170 %	≥ 213 %

Water heating energy efficiency class in colder and hotter climate conditions

Colder: ³ 0.2 x ² = %

Hotter: ³ 0.4 x ² = %

The energy efficiency of the set of products indicated in this fiche may not reflect the actual energy efficiency after installation since such efficiency is affected by additional factors, such as the heat loss in the distribution system and the size of the products compared to the size and features of the building.

Parameters for filling in DHW package package fiche.

Parameter	Victrix Tera 24 Plus
'I'	--
'II'	*
'III'	*

* to be determined according to Regulation 811/2013 and transient calculation methods as per Notice of the European Community no. 207/2014.

60

Domestic hot water production system package fiche.

Water heating energy efficiency of combination boiler

%

Stated load profile:

Solar contribution

From the board of the solar device

Auxiliary electricity

$(1.1 \times \text{---} - 10\%) \times \text{---} - \text{---} = + \text{---} \%$

Water heating energy efficiency of the set in average climate conditions

%

Water heating energy efficiency class of the set in average climate conditions

	<input type="checkbox"/>	<input type="checkbox"/>	<input type="checkbox"/>	<input type="checkbox"/>	<input type="checkbox"/>	<input type="checkbox"/>	<input type="checkbox"/>	<input type="checkbox"/>	<input type="checkbox"/>	<input type="checkbox"/>
	G	F	E	D	C	B	A	A ⁺	A ⁺⁺	A ⁺⁺⁺
<input type="checkbox"/> M	< 27 %	≥ 27 %	≥ 30 %	≥ 33 %	≥ 36 %	≥ 39 %	≥ 65 %	≥ 100 %	≥ 130 %	≥ 163 %
<input type="checkbox"/> L	< 27 %	≥ 27 %	≥ 30 %	≥ 34 %	≥ 37 %	≥ 50 %	≥ 75 %	≥ 115 %	≥ 150 %	≥ 188 %
<input type="checkbox"/> XL	< 27 %	≥ 27 %	≥ 30 %	≥ 35 %	≥ 38 %	≥ 55 %	≥ 80 %	≥ 123 %	≥ 160 %	≥ 200 %
<input type="checkbox"/> XXL	< 28 %	≥ 28 %	≥ 32 %	≥ 36 %	≥ 40 %	≥ 60 %	≥ 85 %	≥ 131 %	≥ 170 %	≥ 213 %

Water heating energy efficiency class in colder and hotter climate conditions

Colder: $\text{---} \times 0.2 = \text{---} \%$

Hotter: $\text{---} \times 0.4 = \text{---} \%$

The energy efficiency of the set of products indicated in this fiche may not reflect the actual energy efficiency after installation since such efficiency is affected by additional factors, such as the heat loss in the distribution system and the size of the products compared to the size and features of the building.

61

Follow us

Immergas Italia



immergas.com

Immergas S.p.A.
42041 Brescello (RE) - Italy
Tel. 0522.689011
Fax 0522.680617

Certified company ISO 9001

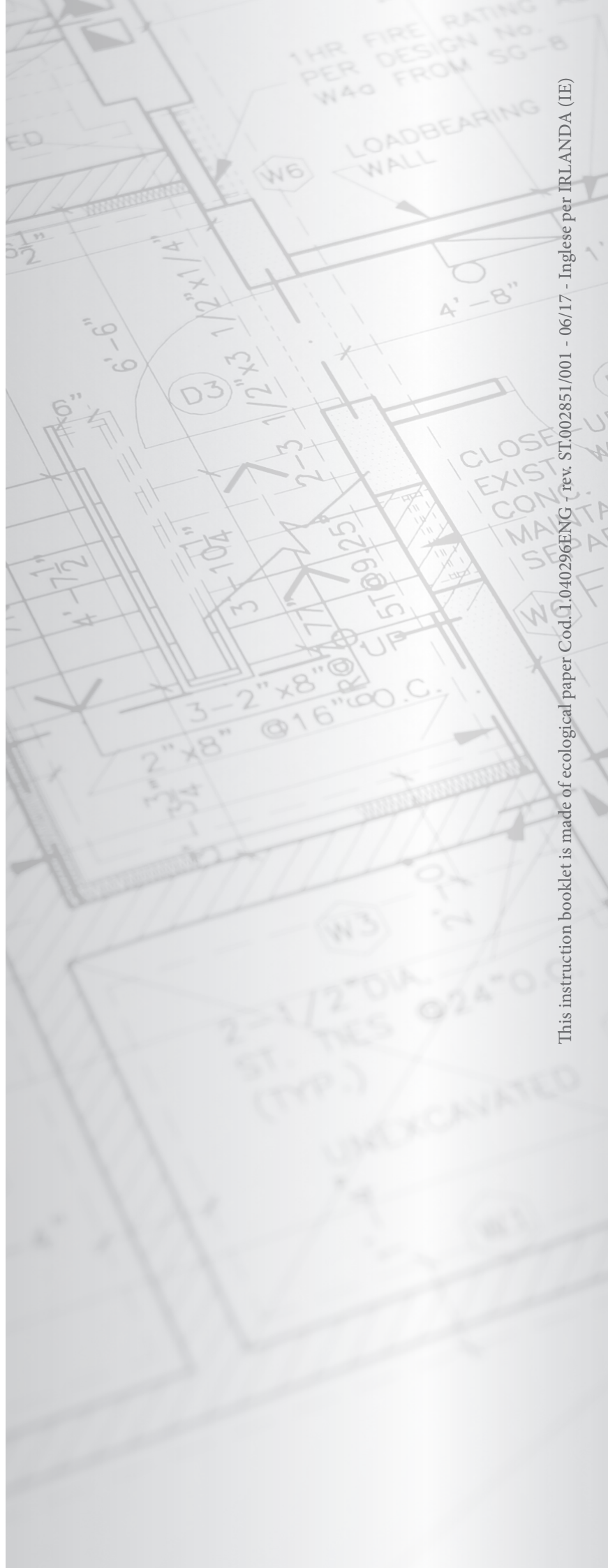

This instruction booklet is made of ecological paper Cod. I.040296ENG - rev. ST.002851/001 - 06/17 - Inglese per IRLANDA (IE)