

PHAROS: MODEL SPECIFICATIONS

1. TECHNICAL DATA	2
2. PRE-INSTALLATION	3
3. INSTALLATION	5
4. OPERATION	9
5. TESTING	10

Keep for future use

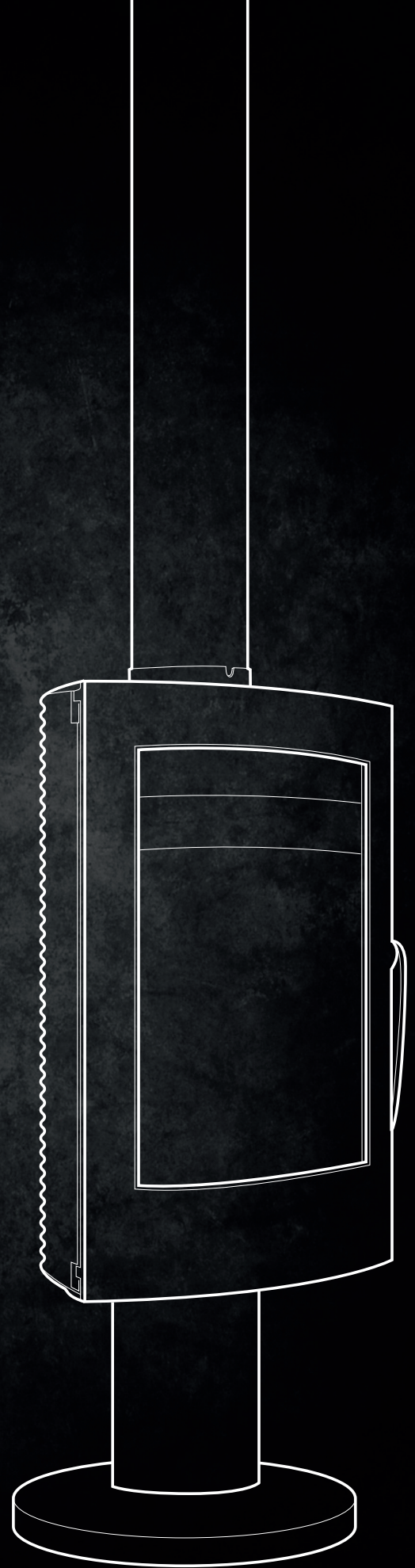

INVICTA

obolico

1. TECHNICAL DATA

WEIGHT AND DIMENSIONS:

Dimensions Firebox	W531 x H1250 x D530mm
Firebox weight	167kg
Flue kit	Standard 7"/9"/11"

DETERMINED UNDER TEST CONDITIONS:

Nominal thermal output	9kW
Efficiency (Australian Test)	60%
Emissions (Australian Test)	1.2g/kg

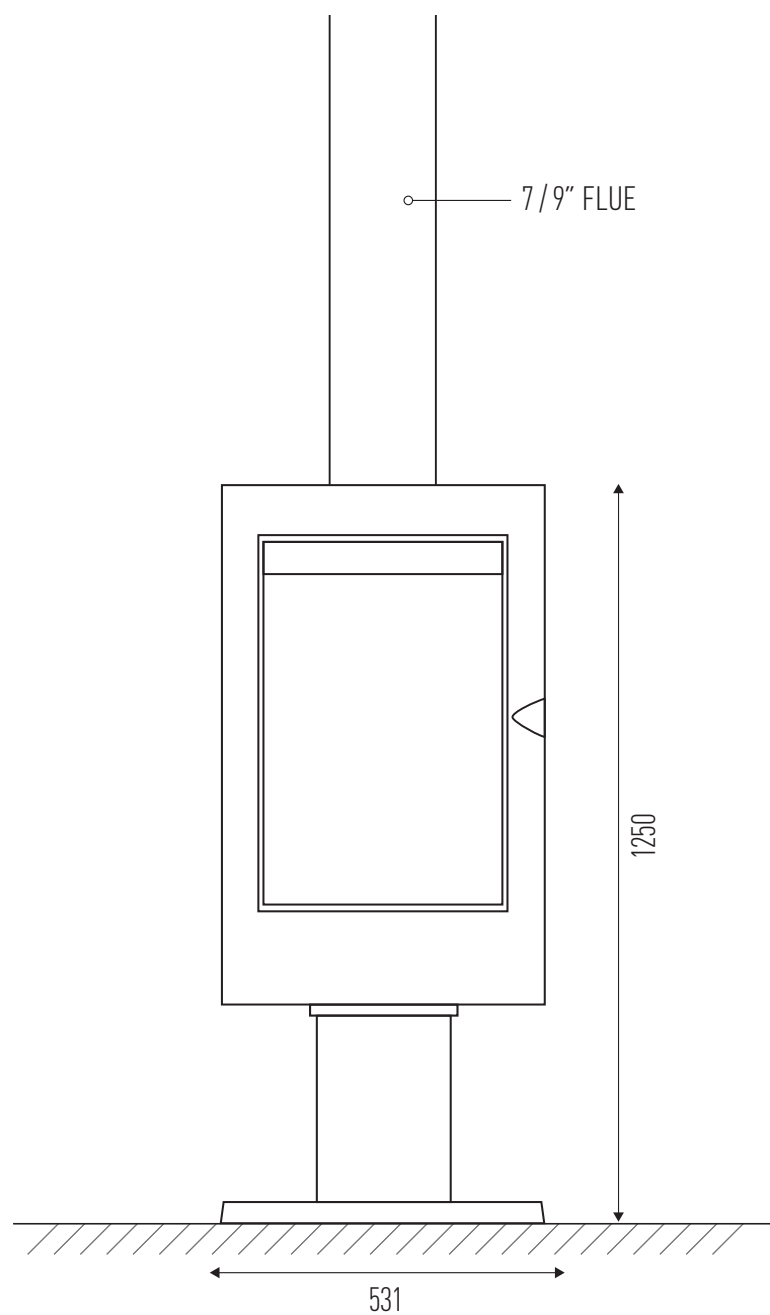

2. PRE-INSTALLATION

Congratulations on your purchase of the Pharos. This appliance should be installed and checked by a qualified professional. Ensure you have read the operation guidelines thoroughly prior to first use. For any questions or concerns please contact Oblica on 03 9416 0400.

The installation process is outlined below:

- Determine position of firebox and flue carefully observing the clearances described within this section
- Install the external flue
- Install the internal flue and engage the firebox
- Ensure the floor has adequate protection

CAUTION:

Using components or parts other than those provided by the manufacturer or modifying the specification of components may result in inferior or unsafe operation. If such action is necessary, consult the manufacturer in the first instance.

WARNING:

- The appliance and flue-system must be installed in accordance with AS/NZS 2918 and the relevant building code or codes.
- Any modification of the appliance that has not been approved in writing by the testing authority will be in breach of the approval granted for compliance with AS/NZS 4013.
- Once the flue has been installed and approved by a professional installer, the flue must not be modified in any way.

2. PRE-INSTALLATION (CONTINUED)

MINIMUM CLEARANCE — INTERNAL

2.1 Clearance from non-combustible surfaces (eg masonry)

100mm minimum clearance is required from fully non-combustible surfaces.

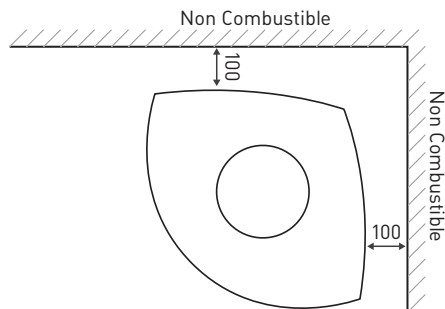

2.2 Clearance from glass

400mm minimum clearance is required from normal non-combustible glass.

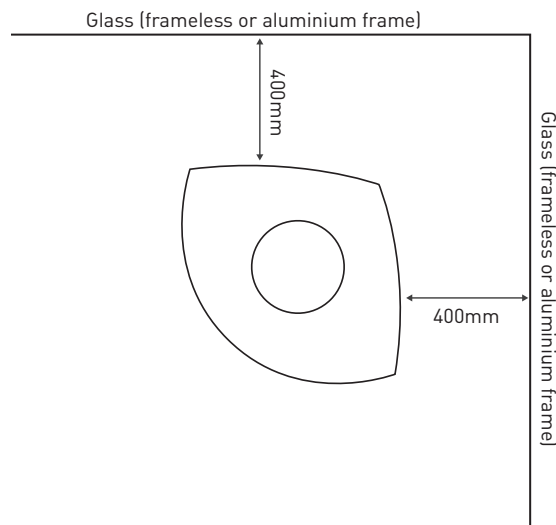

IMPORTANT:

Frames must also be considered. Timber window frames must be treated as combustible surfaces (see 2.3). Aluminium frames can be treated as non-combustible surfaces (see 2.2).

2.3 Clearance from combustible surfaces (eg timber joist & concrete)

Clearances may be reduced with the application of heat shielding to walls in accordance to the Australian Building Code.

For information on heat shielding please contact our office on 03 9416 0400 or email info@oblica.com.au.

Configuration 1 — Parallel installation

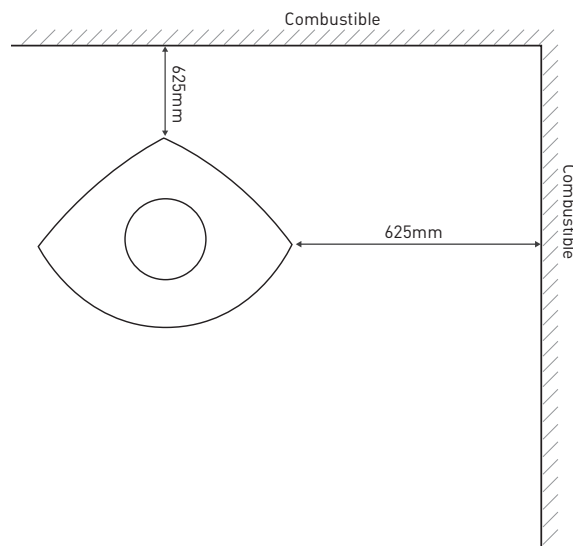

Configuration 2 — Corner installation

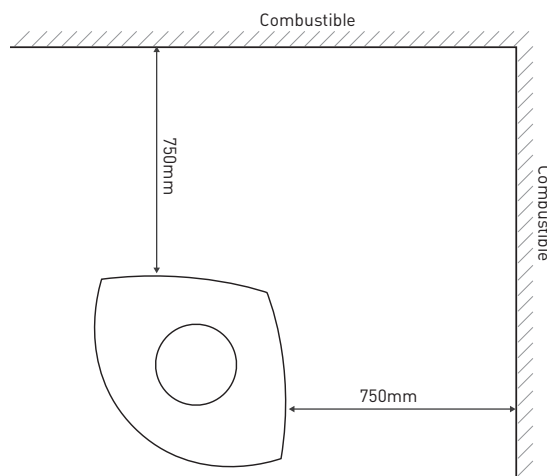

3. INSTALLATION

3.1 Typical flue kit installation

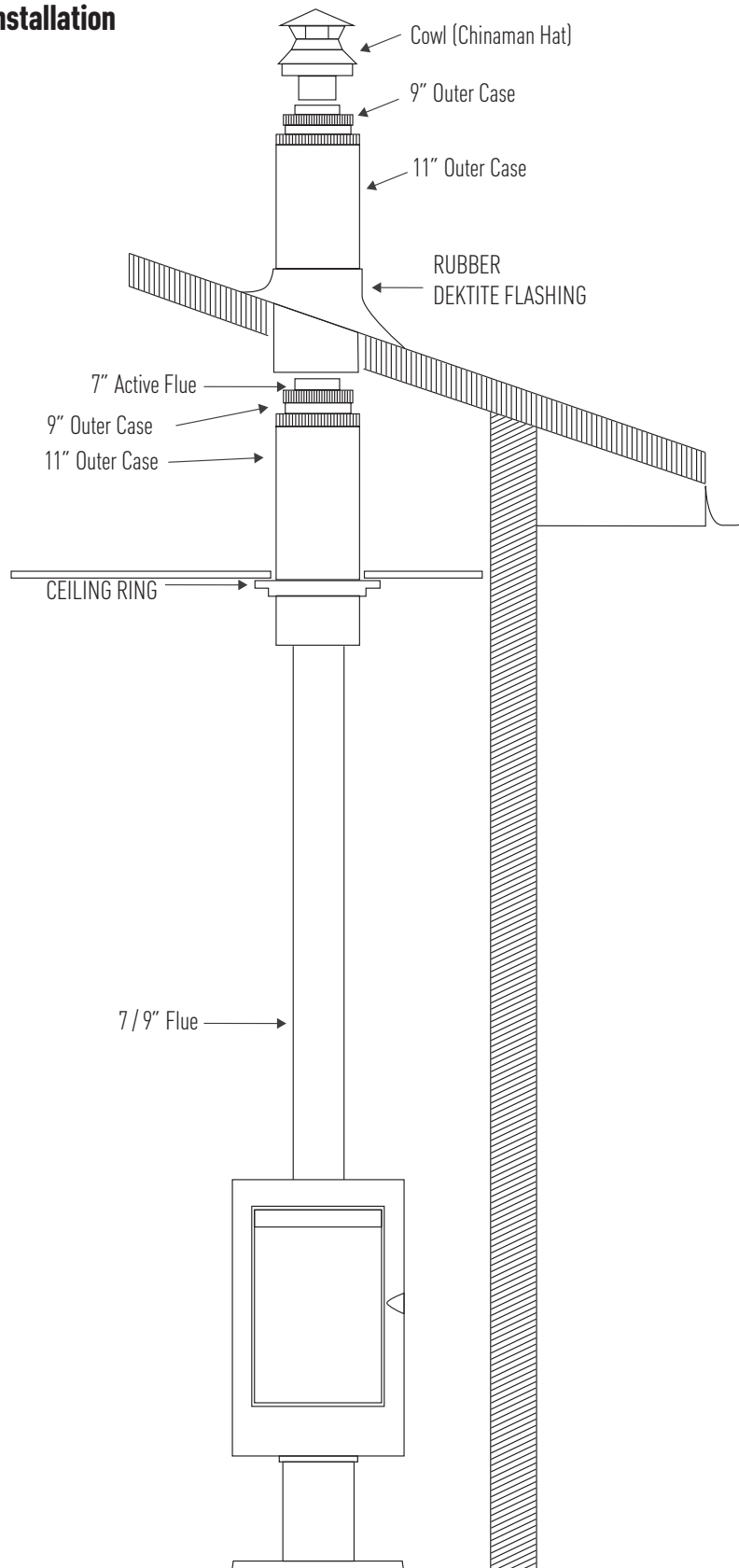

3. INSTALLATION (CONTINUED)

3.2 Installing the external flue

1. Place the connection piece inside the suspension bracket. This will join the single skin flue below the bracket and the triple skin flue above the bracket which have different diameters.
2. Ensure the triple skin flue is installed as per Australian standards (see diagrams below).

PITCHED ROOF INSTALLATION

The top of the flue must be 400mm higher than the highest point of the roof. Alternatively, there must be a minimum distance of 3 meters from any higher section of roof.

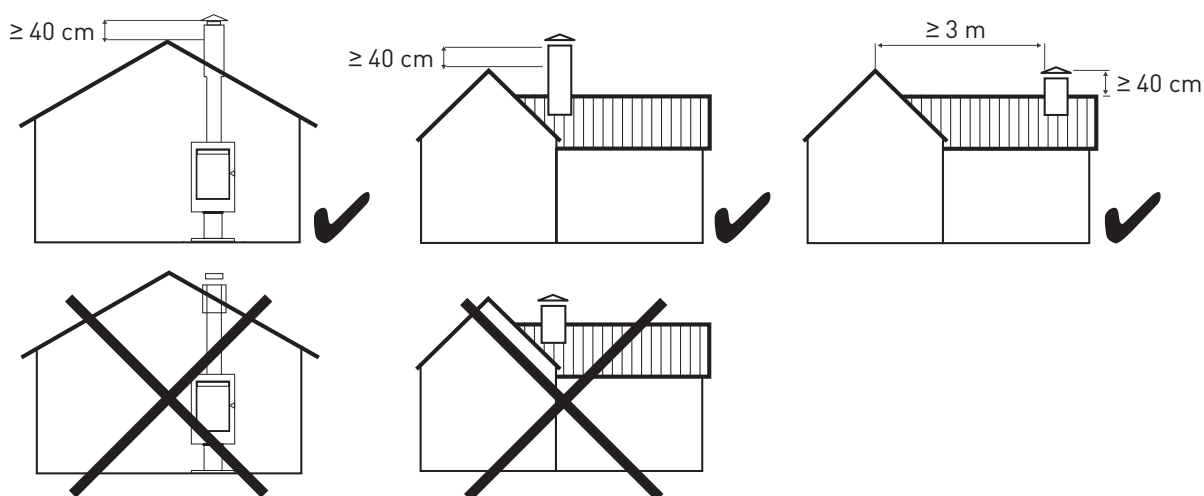

FLAT ROOF INSTALLATION (LESS THAN 5° PITCH)

The top of the flue must be 1200mm above the roofline. Alternatively, there must be a minimum distance of 3 meters from any higher section of roof.

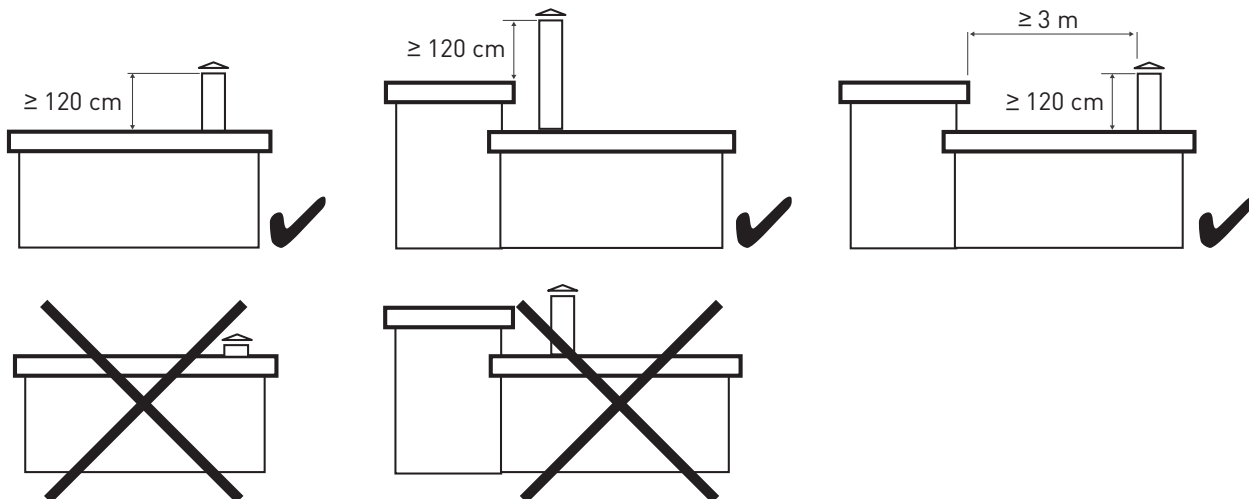

3. INSTALLATION (CONTINUED)

3.3 Protecting the floor

- Any combustible floor beneath a fireplace must have a floor protector that extends minimum 300mm at the front.
- If installed directly on combustible material, the floor protector must be made of a minimum 6mm thick cement sheet. Non-combustible finishes can be applied to the floor protector (tiles, steel sheet, light concrete, etc).
- If the combustible floor is installed on concrete, you can replace the combustible material with non-combustible material laid directly onto the concrete.

FLOOR PROTECTOR LAID ON TIMBER FLOOR

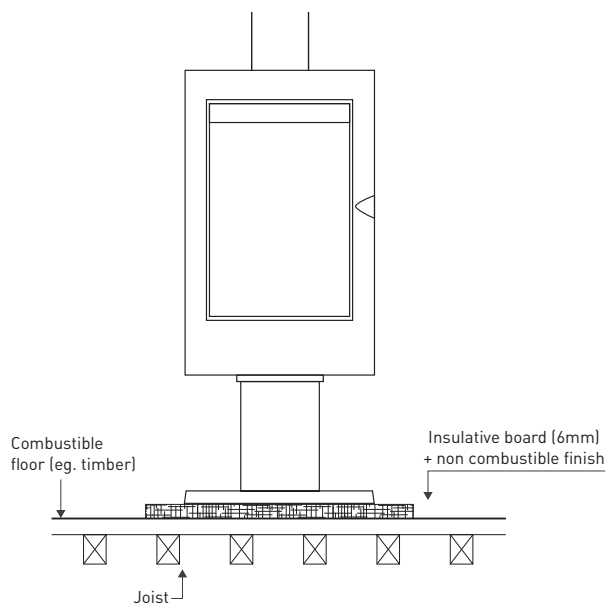

FLOOR PROTECTOR LAID ON JOIST

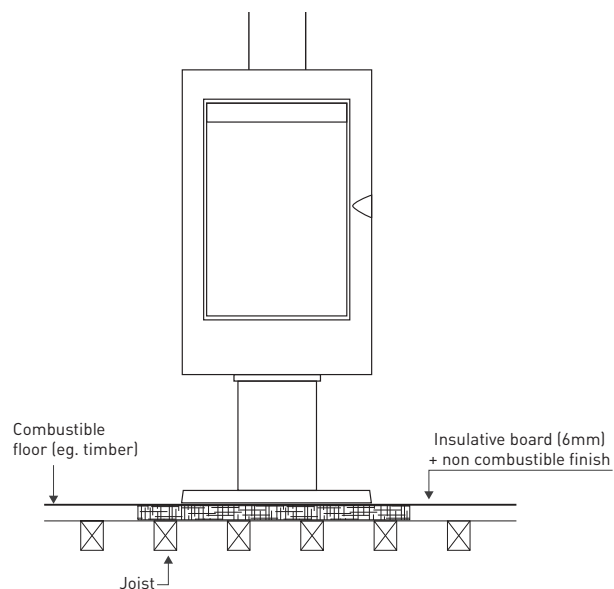

3. INSTALLATION (CONTINUED)

FLOOR PROTECTOR LAID ON CONCRETE

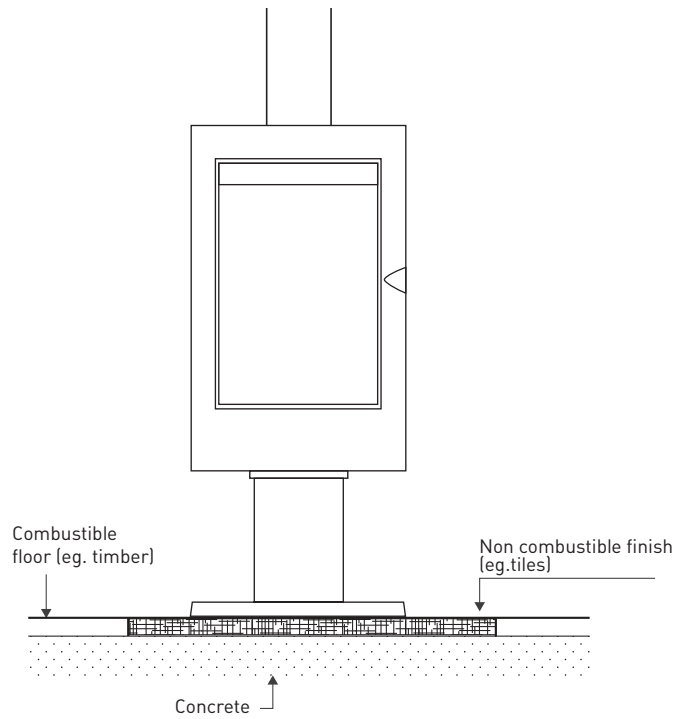

TOP VIEW

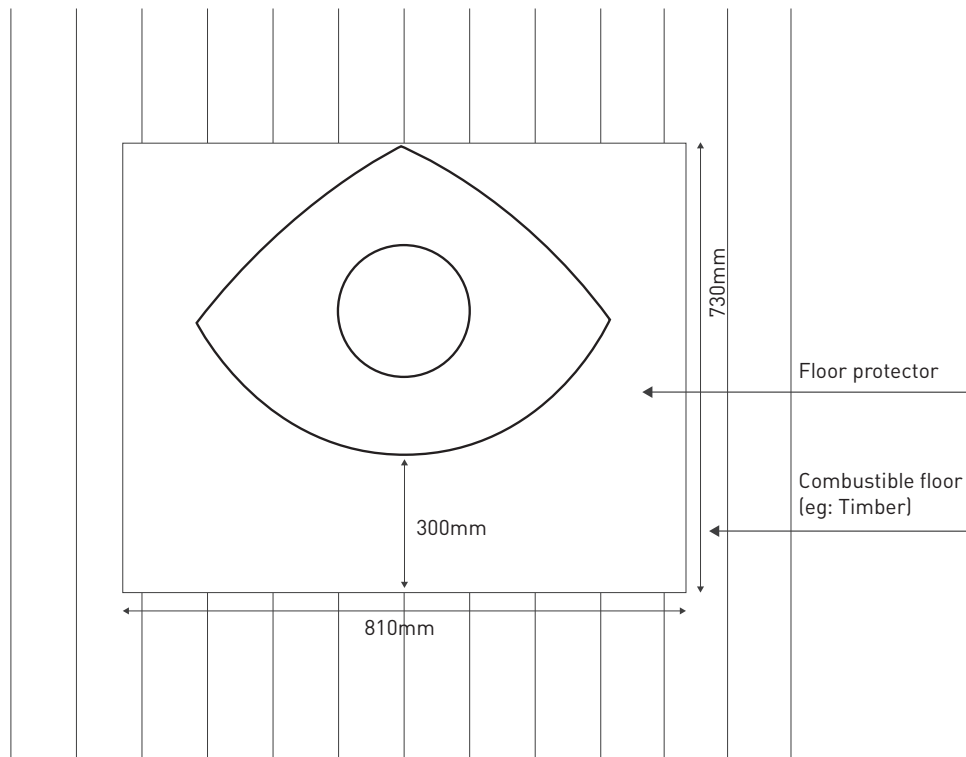

4. OPERATION

4.1 What you should burn

- Untreated, air dried hardwood
- Split logs with a humidity content of less than 20%

4.2 Do not burn

- Trash
- Painted plastic
- Coated or preservative treated wood
- Waste or black coal
- Inflammable liquids
- Fire gels
- Moist wood with a residual humidity content of more than 20% (this may cause sooting of the chimney).

IMPORTANT:

- Misuse may lead to unhealthy and environmentally harmful emissions and will void any warranty or guarantee.
- The maximum load capacity for the Pharos is 10kg of wood.
- Burning only seasoned hardwood helps to protect the environment and lower emissions.

For details of a wood supplier in your area please call our office on 03 9416 0400 or email info@oblica.com.au.

WARNING:

- Do not use flammable liquids or aerosols to start or rekindle the fire.
- Do not use flammable liquids or aerosols in the vicinity of the fireplace when operating.
- Do not store fuel within prescribed installation clearance distances.
- The use of some types of preservative-treated woods as a fuel can be hazardous.

5. TESTING

TEST REPORT NO HCMG/15/041

TESTING LABORATORY: HRL Technology

MANUFACTURER: Invicta

MODEL: Pharos fireplace

WORK REQUESTED: Assessment of appliance to AS/NZS 4012:2014 for determination of Power Output and Efficiency and AS/NZS 4013:2014 for Flue Gas Emission using hardwood fuel.

ISSUE DATE: 23/07/2015

INVESTIGATING OFFICER: Steve Marland

RESULTS: The Pharos solid fuel burning appliance produced an appliance particulate emissions factor of 1.2g/kg and an average efficiency of 60% for all burn rates, using hardwood that complies to AS/NZS 4014.1, when tested according to joint AS/NZS 4012, AS/NZS 4013 (2014).

CONCLUSION: The Pharos solid fuel burning appliance complies with the requirement of a combined efficiency of not less than 55% and a particulate emissions factor of not greater than 2.5g/kg of hardwood that complies to AS/NZS 4014.1 in AS/NZS 4013 (2014).